



GP LAM[®] LVL



GP LAM[®] LVL FEATURES & BENEFITS

- Resists shrinking, warping, splitting and checking
- 2.0E has exceptional design values for bending, stiffness and shear strength
- FiberGuard[®] sealant provides short-term protection from moisture during the construction phase
- Available in 1 3/4" and 3 1/2" thicknesses (1 1/2" by special order), and depths from 3 1/2" to 24"; for 3 1/2" thickness or other depths, contact GP for availability
- Available in value lengths from 24' to 48' (lengths up to 60' by special order)

GRADE	THICKNESS	DEPTH
2.0E	1 3/4", 3 1/2"	7 1/4", 9 1/4", 9 1/2", 11 1/4", 11 7/8", 14", 16", 18", 24"

Lengths: up to 60 feet.

Referenced dimensions are nominal and used for design purposes.



GP LAM[®] LVL BEARING DETAILS

- Confirm the actual required bearing is provided by a support that has adequate strength to carry the load.
- Minimum bearing length for GP Lam LVL beams and headers is 1½" for end and 3" for intermediate bearings. Size bearing for applied loads.
- For fastening recommendations for multiple-ply GP Lam LVL members, see pages 47-48.

BEAM-TO-BEAM CONNECTION

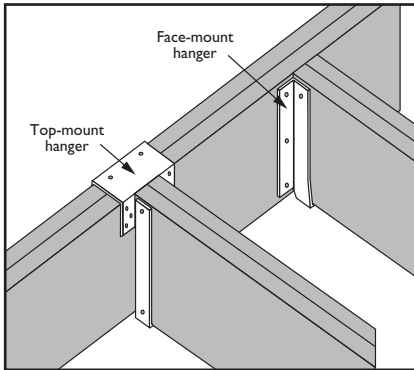

Hangers must be properly installed to achieve full capacity.

BEARING ON WOOD COLUMN

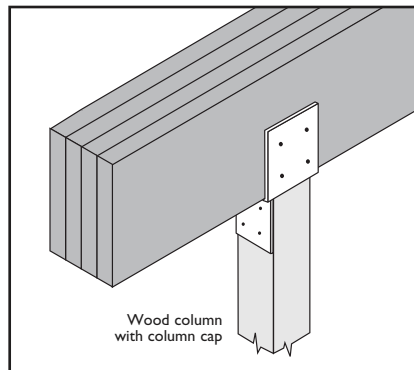

Where column caps are not used, side plates may be required for lateral restraint and/or load transfer. Consult designer of record. See tables on page 51 and 52 for column cap information.

BEARING ON STEEL COLUMN

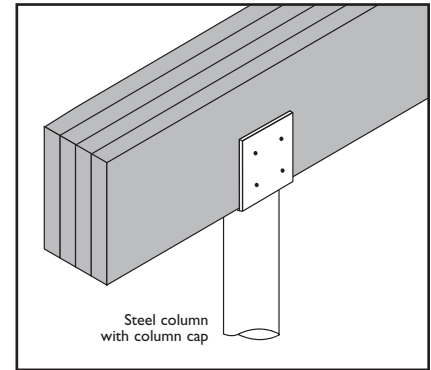

POCKET IN CONCRETE OR MASONRY

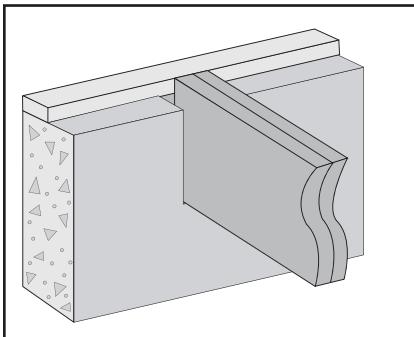

Prevent direct contact of GP Lam LVL with concrete or masonry, or protect per code. Consult local building code for additional requirements.

BEARING ON EXTERIOR WALL

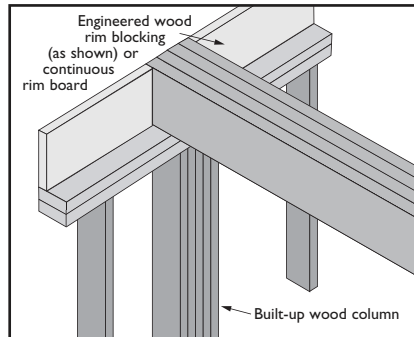

Consult local building code for requirements.

BEARING FOR DOOR OR WINDOW HEADER

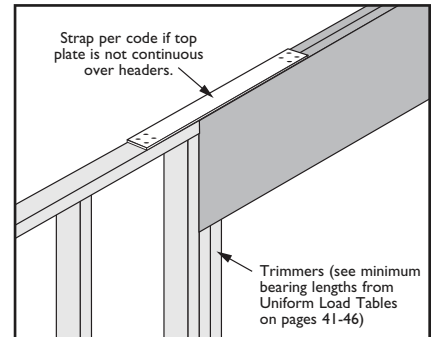

See "Bearing Length Requirements" on page 39.

LOW END HIP BEARING

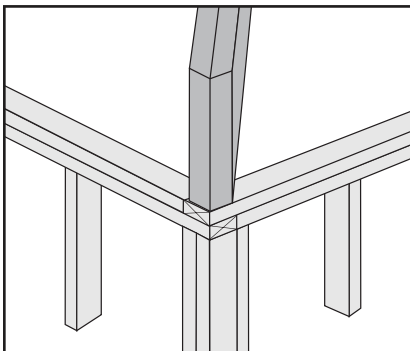

Hip beam must bear completely on plate or post. Seat cut must not extend past inside face of bearing.

HIGH END HIP BEARING

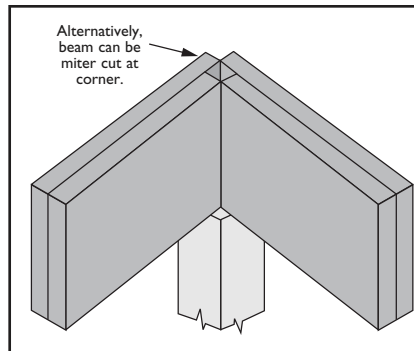

Hip beam must bear on post or in properly designed hanger or other connection.

SEAT CUT / NOTCHING

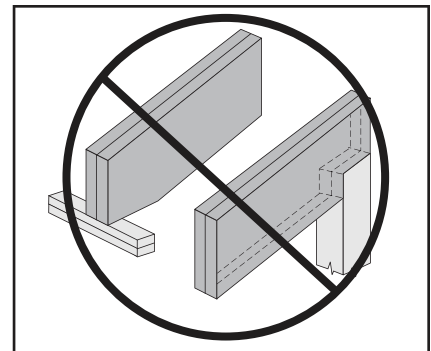

Seat cut must not extend past inside face of bearing. Do not notch beams at bearing.

GP LAM® LVL HANDLING & INSTALLATION

- GP Lam® LVL shall not be stored in direct contact with the ground and must be protected from weather. Provide air circulation under covering and around stacks of materials.
- Bundles must be stored level and must not be opened until time of installation.
- Stack and handle GP Lam LVL flatwise.
- Handlers and installers should use appropriate personal protective equipment such as gloves and goggles. An MSDS is available at www.buildgp.com.
- Engineered lumber must not be installed in direct contact with concrete or masonry construction or shall be protected per code and shall be used in covered, dry use conditions only (moisture content is less than 16%).
- Minimum bearing length for GP Lam LVL beams and headers: end bearing 1½", intermediate bearing 3". Size for applied loads.
- GP Lam LVL beams and headers must be restrained against rotation at ends and supports and the top (or compression edge) must be laterally supported by perpendicular framing or bracing at 24" on-center or closer.
- 1¾" GP Lam LVL beams deeper than 14" must only be used in multiple-piece members.
- Nails installed in the narrow face of GP Lam LVL shall not be spaced closer than 4" (10d common nails) or 3" (8d common nails).
- Multiple piece GP Lam LVL may not be stagger-spliced as is sometimes done with dimension lumber. If the required length of a multiple-span beam exceeds the available length of the LVL, the LVL beams must be installed so as to butt together over a common bearing.
- GP Lam LVL is manufactured without camber or specific vertical orientation. It may be installed with the identifying stamps on the side faces reading right side up or upside down.
- Strength and stiffness properties of GP Lam LVL exceed those of typical dimension lumber. It may be possible to substitute GP Lam LVL for dimension lumber roof members in code-prescribed conventional light-frame construction, but design of conventional construction is beyond the scope of this product guide and of Georgia-Pacific Engineered Lumber Technical Services.
- When nail type is not specified in this guide, use common, box or sinker.
- To help safeguard the structural integrity of connections with preservative or fire-retardant treated wood, use connectors and hardware as required by code and type of treatment.

As a minimum requirement, hot-dipped galvanized coated fasteners should conform to ASTM Standard A 153 and hot-dipped galvanized coated connectors should conform to ASTM Standard A 653 (Class G-185). In demanding applications, or in highly corrosive environments, stainless steel fasteners and connectors should be utilized and may, in fact, be required by building codes. Most commonly available electroplated galvanized fasteners do not have a sufficient coating of zinc and are not recommended. Aluminum should not be used in direct contact with preservative treated wood. Never mix galvanized steel with stainless steel in the same connection.

2.0E GP LAM LVL FLOOR BEAMS

This table shows the size (e.g.: 2-11¼" = 2 plies of 1¾"x11¼") of beams needed to support loads of one floor only, i.e., a second story floor or one story floor over a basement. (See drawing at right.)

When floor joists span continuously from wall to wall (not cut at beam) this table requires that "B" be not less than 45%, or greater than 55% of "A".

Example: If "A" = 32', "B" must be between 14.4' (32x.45) and 17.6' (32x.55)

For non-conforming situations, use FASTBeam® analysis and selection software or contact Georgia-Pacific.

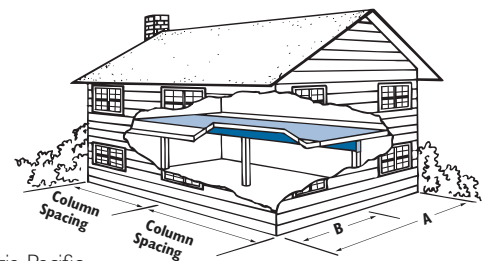

		COLUMN OR SUPPORT SPACING (CENTER-TO-CENTER)									
		11'	12'	13'	14'	15'	16'	17'	18'	19'	20'
TOTAL FLOOR JOIST SPAN "A"	24'	2-11¼" 3-9¼"	2-11¼" 3-9½"	2-11⅞" 3-11¼"	2-14" 3-11¼"	2-14" 3-11⅞"	2-16"+ 3-14"	2-16"+ 3-14"	2-18"+ 3-16"	2-18"+ 3-16"	2-18"+ 3-16"
	28'	2-11¼" 3-9¼"	2-11⅞" 3-11¼"	2-14"+ 3-11¼"	2-14"+ 3-11⅞"	2-16"+ 3-14"	2-16"+ 3-14"	2-16"+ 3-14"	2-18"+ 3-16"	2-18"+ 3-16"	3-16"
	32'	2-11¼" 3-11¼"	2-14"+ 3-11¼"	2-14"+ 3-11⅞"	2-14"+ 3-14"	2-16"+ 3-14"	2-16"+ 3-14"	2-18"+ 3-16"	2-18"+ 3-16"	3-16"+	3-18"+
	36'	2-11⅞"+ 3-11¼"	2-14"+ 3-11¼"	2-14"+ 3-11⅞"	2-16"+ 3-14"	2-16"+ 3-14"	2-18"+ 3-14"	3-16"+	3-16"+	3-18"+	3-18"+
	40'	2-11⅞"+ 3-11¼"	2-14"+ 3-11¼"	2-14"+ 3-14"	2-16"+ 3-14"	2-16"+ 3-14"	3-16"+	3-16"+	3-16"+	3-18"+	3-18"+

NOTES:

1. Table is based on continuous floor joist span and simple or continuous beam span conditions. If floor joists are not continuous above the beam, take the sum of the joist spans then multiply by 0.8. This is the total floor joist span to consider.
2. Required end bearing length (based on 565 psi) is 3.0" unless the subscript + is shown. In that case, 4.5" is required.
3. At intermediate supports of continuous spans, use the following guidelines or refer to page 39.
 - 7½" bearing length for beams requiring 3" bearing at the beam ends
 - 10½" bearing length for beams requiring 4½" bearing at the beam ends
4. All headers require full-width bearing support, e.g., 2x6 for 5¼", 3-ply members. The adequacy of supporting columns to be verified by others.
5. Table is based on residential floor loading of 40 psf live load and 12 psf dead load.
6. Live load reductions have been applied per IBC section 1607.9.1.
7. Deflection is limited to L/360 at live load and L/240 at total load.
8. For other uniform load conditions refer to pages 41-42.
9. A single 3½" thick ply can be substituted for any two 1¾" thick plies.
10. For multiple ply fasteners, see pages 47-48.

2.0E GP LAM® LVL WINDOW AND PATIO DOOR HEADERS, 2-STORY

TWO-STORY APPLICATIONS

This table shows the size (e.g. 2-1 1/4" = 2 plies of 1 3/4" x 1 1/4") of beams needed to support the combined loads from a wall, second story floor (1/4 of total floor joist span) and various roof truss spans with a 2' soffit. If the soffit exceeds 2', additional design is necessary. For non-conforming situations, use FASTBeam® analysis and selection software or contact Georgia-Pacific.

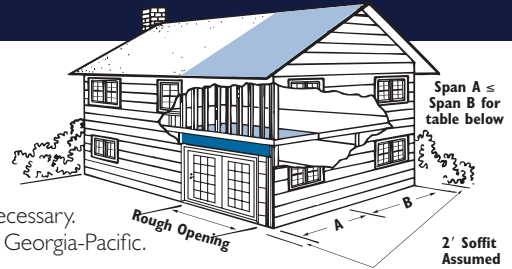

ROOF LOADING		SNOW (115%)										NON-SNOW (125%)											
		25 PSF LL + 20 PSF DL					40 PSF LL + 20 PSF DL					20 PSF LL + 15 PSF DL			20 PSF LL + 25 PSF DL								
ROUGH OPENING		6'	8'	9'	10'	12'	6'	8'	9'	10'	12'	6'	8'	9'	10'	12'	6'	8'	9'	10'	12'		
ROOF TRUSS SPAN WITH 2' SOFFIT ASSUMED	20'	1-9/16" 2-7/16"	1-11/16" 2-9/16" 3-7/16"	1-14" 2-11/16" 3-9/16"	2-11/16"	2-16" 3-14"	1-9/16" 2-7/16"	1-11/16" 2-9/16"	2-11/16" 3-9/16"	2-14" 3-11/16"	2-16" 3-14"	1-7/16" 2-9/16" 3-7/16"	1-11/16" 2-9/16" 3-9/16"	1-14" 2-11/16" 3-9/16"	2-14" 3-11/16"	2-16" 3-14"	1-9/16" 2-7/16"	1-11/16" 2-9/16" 3-9/16"	1-14" 2-11/16" 3-9/16"	2-11/16"	2-16" 3-14"	2-11/16" 3-14"	
	24'	1-9/16" 2-7/16"	1-11/16" 2-9/16"	1-14" 2-11/16" 3-9/16"	2-11/16"	2-16" 3-14"	1-9/16" 2-7/16"	1-11/16" 2-9/16"	2-11/16" 3-9/16"	2-14" 3-11/16"	2-18" 3-14"	1-9/16" 2-7/16"	1-11/16" 2-9/16" 3-9/16"	1-14" 2-11/16" 3-9/16"	2-16" 3-14"	2-18" 3-14"	1-9/16" 2-7/16"	1-11/16" 2-9/16" 3-9/16"	1-14" 2-11/16" 3-9/16"	2-11/16"	2-16" 3-14"	2-11/16" 3-14"	
	28'	1-9/16" 2-7/16"	2-9/16"	2-11/16" 3-9/16"	2-14" 3-11/16"	2-16" 3-14"	1-9/16" 2-7/16"	2-11/16" 3-9/16"	2-11/16" 3-11/16"	2-14" 3-11/16"	2-18" 3-16"	1-9/16" 2-7/16"	1-11/16" 2-9/16" 3-9/16"	1-14" 2-11/16" 3-11/16"	2-16" 3-14"	2-18" 3-16"	1-9/16" 2-7/16"	2-9/16"	2-11/16" 3-9/16"	2-11/16"	2-14" 3-11/16"	2-16" 3-14"	
	32'	1-9/16" 2-7/16"	2-11/16" 3-9/16"	2-11/16"	2-14" 3-11/16"	2-18" 3-16"	2-7/16"	2-11/16" 3-9/16"	2-14" 3-11/16"	2-16" 3-11/16"	2-18" 3-16"	1-9/16" 2-7/16"	1-14" 2-9/16"	2-11/16" 3-9/16"	2-14" 3-11/16"	2-16" 3-14"	2-18" 3-16"	2-7/16"	2-11/16" 3-9/16"	2-11/16"	2-14" 3-11/16"	2-16" 3-14"	2-18" 3-16"
	36'	1-9/16" 2-7/16"	2-11/16" 3-9/16"	2-11/16" 3-11/16"	2-14" 3-11/16"	2-18" 3-16"	2-9/16" 3-7/16"	2-11/16" 3-9/16"	2-14" 3-11/16"	2-16" 3-14"	2-18" 3-16"	1-9/16" 2-7/16"	2-9/16" 3-9/16"	2-11/16" 3-11/16"	2-14" 3-11/16"	2-18" 3-14"	2-18" 3-16"	2-7/16"	2-11/16" 3-9/16"	2-11/16" 3-11/16"	2-14" 3-11/16"	2-16" 3-14"	2-18" 3-16"

NOTES:

- Required end bearing length (based on 625 psi) is 3.0" unless the subscript + is shown. In that case, 4.5" is required.
- All headers require full-width bearing support, e.g., 2x6 for 5/4", 3-ply members. The adequacy of supporting columns to be verified by others.
- Table is based on residential floor loading of 40 psf live load and 12 psf dead load and exterior wall weight of 100 plf.
- A beam line supporting the center of the second floor is assumed.
- Deflection is limited to L/360 and the lesser of L/240 or 5/16" at total load.
- Roof live and dead loads shown are applied vertically to the horizontal projection.
- When using a single ply 1 3/4", consider the effect on hanger capacity, and the available bearing surface the LVL provides to other framing elements.
- A single 3/2" thick ply can be substituted for any two 1 3/4" thick plies.
- For multiple ply fasteners, see pages 47-48.
- This table does not address a brick loaded condition.

2.0E GP LAM LVL GARAGE DOOR HEADERS, 2-STORY

TWO-STORY APPLICATIONS

This table shows the size (e.g. 2-1 1/4" = 2 plies of 1 3/4" x 1 1/4") of beams needed to support the combined loads from a wall, second story floor (1/4 of total floor joist span) and various roof truss spans with a 28 soffit. If the soffit exceeds 2', additional design is necessary. For non-conforming situations, use FASTBeam® analysis and selection software or contact Georgia-Pacific.

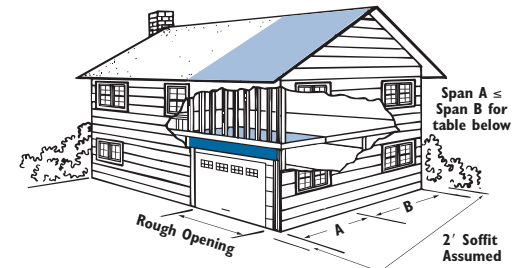

ROOF LOADING		SNOW (115%)									NON-SNOW (125%)											
		25 PSF LL + 20 PSF DL			30 PSF LL + 20 PSF DL			40 PSF LL + 20 PSF DL			20 PSF LL + 15 PSF DL			20 PSF LL + 20 PSF DL			20 PSF LL + 25 PSF DL					
ROUGH OPENING		9'3"	16'3"	18'3"	9'3"	16'3"	18'3"	9'3"	16'3"	18'3"	9'3"	16'3"	18'3"	9'3"	16'3"	18'3"	9'3"	16'3"	18'3"	9'3"	16'3"	18'3"
ROOF TRUSS SPAN WITH 2' SOFFIT ASSUMED	20'	1-11/16" 2-9/16"	2-16" 3-14"	2-18" 3-16"	1-11/16" 2-9/16"	2-16" 3-14"	2-18" 3-16"	2-9/16" 3-9/16"	2-18" 3-14"	3-16"	1-11/16" 2-9/16" 3-7/16"	2-16" 3-14"	2-18" 3-16"	1-11/16" 2-9/16"	2-16" 3-14"	2-18" 3-16"	1-11/16" 2-9/16"	2-16" 3-14"	2-18" 3-16"	2-16" 3-14"	2-18" 3-16"	2-18" 3-16"
	24'	2-9/16"	2-18" 3-14"	3-16"	2-9/16" 3-9/16"	2-18" 3-16"	3-16"	2-11/16" 3-9/16"	3-16"	3-18"	1-11/16" 2-9/16"	2-16" 3-14"	2-18" 3-16"	1-11/16" 2-9/16"	2-16" 3-14"	2-18" 3-16"	2-9/16"	2-16" 3-14"	2-18" 3-16"	2-9/16"	2-18" 3-14"	3-16"
	28'	2-11/16" 3-9/16"	3-16"	3-18"	2-11/16" 3-9/16"	3-16"	3-18"	2-11/16" 3-9/16"	3-16"	3-18"	2-9/16"	2-16" 3-14"	2-18" 3-16"	2-9/16" 3-9/16"	2-18" 3-16"	3-16"	2-11/16" 3-9/16"	2-18" 3-16"	3-16"	2-11/16" 3-9/16"	3-16"	3-18"
	32'	2-11/16" 3-9/16"	3-16"	3-18"	2-11/16" 3-9/16"	3-16"	3-18"	2-11/16" 3-9/16"	3-16"	3-18"	2-9/16"	2-16" 3-14"	2-18" 3-16"	2-11/16" 3-9/16"	2-18" 3-16"	3-16"	2-11/16" 3-9/16"	2-18" 3-16"	3-16"	2-11/16" 3-9/16"	3-16"	3-18"
	36'	2-11/16" 3-9/16"	3-16"	3-18"	2-11/16" 3-9/16"	3-16"	3-18"	2-11/16" 3-9/16"	3-16"	3-18"	2-11/16"	2-11/16" 3-9/16"	2-16" 3-14"	2-11/16" 3-9/16"	2-18" 3-16"	3-16"	2-11/16" 3-9/16"	2-18" 3-16"	3-16"	2-11/16" 3-9/16"	3-16"	3-18"

NOTES:

- Required end bearing length (based on 625 psi) is 3.0" unless the subscript + is shown. In that case, 4.5" is required.
- All headers require full-width bearing support, e.g., 2x6 for 5/4", 3-ply members. The adequacy of supporting columns to be verified by others.
- Table is based on residential floor loading of 40 psf live load and 12 psf dead load and exterior wall weight of 100 plf.
- A beam line supporting the center of the second floor is assumed.
- Deflection is limited to L/360 at live load and L/240 at total load.
- Roof live and dead loads shown are applied vertically to the horizontal projection.
- When using a single ply 1 3/4", consider the effect on hanger capacity, and the available bearing surface the LVL provides to other framing elements.
- A single 3/2" thick ply can be substituted for any two 1 3/4" thick plies.
- For multiple ply fasteners, see pages 47-48.
- This table does not address a brick loaded condition.

2.0E GP LAM® LVL WINDOW AND PATIO DOOR HEADERS, ROOF ONLY

ROOF APPLICATIONS

This table shows the size (e.g.: 2-1 1/4" = 2 plies of 1 3/4" x 1 1/4") of headers needed to support various roof truss spans with 2' soffit. If the soffit is greater than 2', additional design is necessary. For non-conforming situations, use FASTBeam® analysis and selection software or contact Georgia-Pacific.

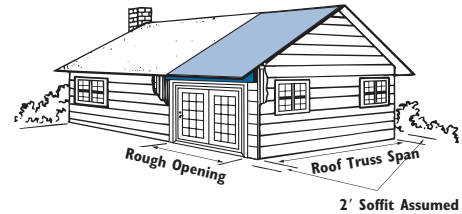

ROOF LOADING		SNOW (115%)										NON-SNOW (125%)									
		25 PSF LL + 20 PSF DL					40 PSF LL + 20 PSF DL					20 PSF LL + 15 PSF DL					20 PSF LL + 25 PSF DL				
ROUGH OPENING		6'	8'	9'	10'	12'	6'	8'	9'	10'	12'	6'	8'	9'	10'	12'	6'	8'	9'	10'	12'
ROOF TRUSS SPAN WITH 2' SOFFIT ASSUMED	20'	1-7/8"	1-9/16"	1-11/16"	1-14"	2-14"	1-7/8"	1-11/16"	1-11/16"	1-14"	2-14"	1-7/8"	1-9/16"	1-9/16"	1-11/16"	1-14"	1-7/8"	1-9/16"	1-9/16"	1-11/16"	1-14"
	24'	1-7/8"	1-9/16"	1-11/16"	1-14"	2-14"	1-7/8"	1-11/16"	1-14"	2-9/16"	2-14"	1-7/8"	1-9/16"	1-11/16"	1-11/16"	2-11/8"	1-7/8"	1-9/16"	1-11/16"	1-14"	2-14"
	28'	1-7/8"	1-11/16"	1-11/16"	1-14"	2-14"	1-9/16"	1-11/16"	1-14"	2-9/16"	2-16"	1-7/8"	1-9/16"	1-11/16"	1-14"	2-14"	1-7/8"	1-11/16"	1-11/16"	1-14"	2-14"
	32'	1-7/8"	1-11/16"	1-14"	1-14"	2-14"	1-9/16"	1-11/16"	1-14"	2-9/16"	2-16"	1-7/8"	1-9/16"	1-11/16"	1-14"	2-14"	1-7/8"	1-11/16"	1-14"	1-14"	2-14"
	36'	1-9/16"	1-11/16"	1-14"	1-14"	2-16"	1-9/16"	2-9/16"	2-11/16"	2-14"	2-18"	1-7/8"	1-11/16"	1-11/16"	1-14"	2-14"	1-9/16"	1-11/16"	1-14"	1-14"	2-16"

NOTES:

- Required bearing length (based on 625 psi) is 3.0' unless the subscript + is shown. In that case, 4.5" is required.
- All headers require full-width bearing support, e.g., 2x6 for 5 1/4", 3-ply members. The adequacy of supporting columns to be verified by others.
- Deflection is limited to L/240 at live load and the lesser of L/180 or 5/16" at total load.
- Roof live and dead loads shown are applied vertically to the horizontal projection.
- When using a single ply 1 3/4", consider the effect on hanger capacity, and the available bearing surface the LVL provides to other framing elements.
- A single 3/8" thick ply can be substituted for any two 1/4" thick plies.
- For multiple ply fasteners, see pages 47-48.

2.0E GP LAM LVL GARAGE DOOR HEADERS, ROOF ONLY

ROOF APPLICATIONS

This table shows the size (e.g.: 2-1 1/4" = 2 plies of 1 3/4" x 1 1/4") of headers needed to support various roof truss spans with 2' soffit. If the soffit is greater than 2', additional design is necessary. For non-conforming situations, use FASTBeam® analysis and selection software or contact Georgia-Pacific.

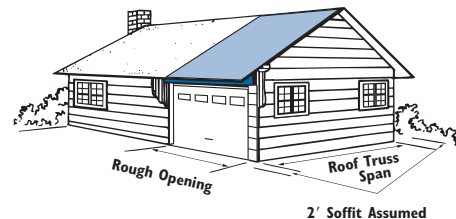

ROOF LOADING		SNOW (115%)									NON-SNOW (125%)								
		25 PSF LL + 20 PSF DL			30 PSF LL + 20 PSF DL			40 PSF LL + 20 PSF DL			20 PSF LL + 15 PSF DL			20 PSF LL + 25 PSF DL					
ROUGH OPENING		9'3"	16'3"	18'3"	9'3"	16'3"	18'3"	9'3"	16'3"	18'3"	9'3"	16'3"	18'3"	9'3"	16'3"	18'3"			
ROOF TRUSS SPAN WITH 2' SOFFIT ASSUMED	20'	1-9/16"	2-11/8"	2-14"	1-9/16"	2-14"	2-14"	1-11/16"	2-9/16"	2-14"	1-9/16"	1-14"	2-11/8"	1-9/16"	2-7/16"	2-14"			
	24'	1-9/16"	2-14"	2-14"	1-11/16"	2-14"	2-16"	1-11/16"	2-9/16"	2-14"	1-9/16"	2-11/16"	2-14"	1-9/16"	2-14"	2-14"			
	28'	1-11/16"	2-14"	2-16"	1-11/16"	2-14"	2-16"	1-11/16"	2-9/16"	2-16"	1-9/16"	2-11/8"	2-14"	1-9/16"	2-14"	2-14"			
	32'	1-11/16"	2-14"	2-16"	1-11/16"	2-14"	2-16"	2-9/16"	2-16"	2-18"	1-9/16"	2-14"	2-14"	1-11/16"	2-14"	2-16"			
	36'	1-11/16"	2-16"	2-16"	1-14"	2-16"	2-18"	2-9/16"	3-14"	3-16"	1-9/16"	2-14"	2-14"	1-11/16"	2-14"	2-16"			

NOTES:

- Required bearing length (based on 625 psi) is 3.0' unless the subscript + is shown. In that case, 4.5" is required.
- All headers require full-width bearing support, e.g., 2x6 for 5 1/4", 3-ply members. The adequacy of supporting columns to be verified by others.
- Deflection is limited to L/240 at live load and L/180 at total load.
- Roof live and dead loads shown are applied vertically to the horizontal projection.
- When using a single ply 1 3/4", consider the effect on hanger capacity, and the available bearing surface the LVL provides to other framing elements.
- A single 3/8" thick ply can be substituted for any two 1/4" thick plies.
- For multiple ply fasteners, see pages 47-48.

GP LAM® LVL ROOF HIP AND VALLEY BEAMS

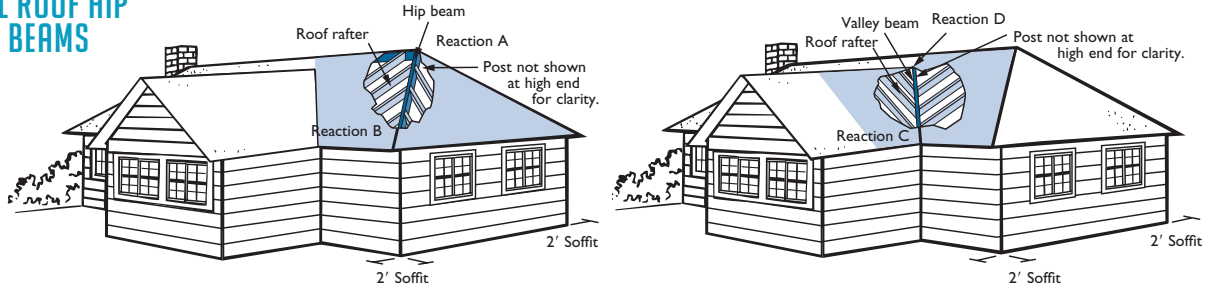

2.0E GP LAM LVL

		ROOF LOADING SNOW (115%)									
		20 PSF LL + 13 PSF DL			30 PSF LL + 13 PSF DL				40 PSF LL + 13 PSF DL		
		ROOF SLOPE			ROOF SLOPE				ROOF SLOPE		
LONGEST HORIZONTAL ROOF RAFTER SPAN (L)		up to 4/12	up to 8/12	up to 12/12	up to 4/12	up to 8/12	up to 12/12	up to 4/12	up to 8/12	up to 12/12	
		12'	No. of 1 3/4" plies - Beam Depth	1 - 11 1/4" 2 - 9 1/4"	1 - 11 1/4" 2 - 9 1/4"	1 - 11 1/4" 2 - 9 1/4"	1 - 11 1/4" 2 - 9 1/4"	1 - 11 1/4" 2 - 9 1/4"	1 - 11 1/8" 2 - 9 1/2" 3 - 9 1/4"	1 - 11 1/4" 2 - 9 1/2" 3 - 9 1/4"	1 - 11 1/8" 2 - 9 1/2" 3 - 9 1/4"
	Order Length	22'	24'	26'	22'	24'	26'	22'	24'	26'	
	Max. React. A&C (lbs)	1881	2049	2326	2401	2570	2846	2921	3089	3366	
	Max. React. B&D (lbs)	1063	1155	1306	1343	1435	1586	1623	1715	1866	
14'	No. of 1 3/4" plies - Beam Depth	1 - 11 7/8" 2 - 9 1/2" 3 - 9 1/4"	1 - 14" 2 - 11 1/4" 3 - 9 1/4"	1 - 14" 2 - 11 1/4" 3 - 9 1/2"	1 - 14" 2 - 11 1/4" 3 - 9 1/4"	1 - 14" 2 - 11 1/4" 3 - 9 1/2"	2 - 11 7/8" 3 - 11 1/4" 4 - 9 1/4"	1 - 14" 2 - 11 1/4" 4 - 9 1/4"	2 - 11 7/8" 3 - 11 1/4" 4 - 9 1/4"	2 - 14" 3 - 11 1/4" 4 - 9 1/4"	
	Order Length	24'	26'	30'	24'	26'	30'	24'	26'	30'	
	Max. React. A&C (lbs)	2491	2716	3090	3184	3414	3830	3920	4149	4568	
	Max. React. B&D (lbs)	1377	1498	1701	1744	1869	2114	2153	2278	2525	
16'	No. of 1 3/4" plies - Beam Depth	2 - 11 7/8" 3 - 11 1/4" 4 - 9 1/4"	2 - 14" 3 - 11 1/4" 4 - 11 1/4"	2 - 14" 3 - 11 7/8" 4 - 11 1/4"	2 - 14" 3 - 11 1/4" 4 - 11 1/4"	2 - 14" 3 - 11 7/8" 4 - 11 1/4"	2 - 14" 3 - 11 7/8" 4 - 11 1/4"	2 - 14" 3 - 11 7/8" 4 - 11 1/4"	2 - 14" 3 - 11 7/8" 4 - 11 1/4"	2 - 16" 3 - 14" 4 - 11 7/8"	
	Order Length	28'	30'	34'	28'	30'	34'	28'	30'	34'	
	Max. React. A&C (lbs)	3239	3580	4067	4176	4473	4961	5069	5367	5870	
	Max. React. B&D (lbs)	1785	1989	2253	2295	2456	2720	2761	2923	3202	
18'	No. of 1 3/4" plies - Beam Depth	2 - 14" 3 - 11 7/8" 4 - 11 1/4"	2 - 14" 3 - 11 1/4" 4 - 11 1/4"	2 - 16" 3 - 14" 4 - 11 1/8"	2 - 16" 3 - 14" 4 - 11 7/8"	2 - 16" 3 - 14" 4 - 11 7/8"	2 - 18" 3 - 16" 4 - 14"	2 - 16" 3 - 14" 4 - 14"	2 - 18" 3 - 16" 4 - 14"	2 - 18" 3 - 16" 4 - 14"	
	Order Length	30'	32'	36'	30'	32'	36'	30'	32'	36'	
	Max. React. A&C (lbs)	4084	4457	5144	5219	5647	6265	6390	6767	7385	
	Max. React. B&D (lbs)	2244	2444	2848	2839	3094	3428	3470	3674	4008	
20'	No. of 1 3/4" plies - Beam Depth	2 - 16" 3 - 14" 4 - 11 1/4"	2 - 18" 3 - 16" 4 - 14"	2 - 18" 3 - 16" 4 - 14"	2 - 18" 3 - 16" 4 - 14"	2 - 18" 3 - 16" 4 - 14"	2 - 24" 3 - 18" 4 - 16"	2 - 18" 3 - 16" 4 - 16"	2 - 24" 3 - 18" 4 - 16"	2 - 24" 3 - 18" 4 - 16"	
	Order Length	34'	36'	40'	34'	36'	40'	34'	36'	40'	
	Max. React. A&C (lbs)	5051	5511	6329	6424	6885	7702	7850	8316	9075	
	Max. React. B&D (lbs)	2778	3026	3494	3485	3733	4201	4244	4497	4907	
22'	No. of 1 3/4" plies - Beam Depth	2 - 18" 3 - 16" 4 - 14"	2 - 24" 3 - 18" 4 - 16"	2 - 24" 3 - 18" 4 - 16"	2 - 24" 3 - 18" 4 - 16"	2 - 24" 3 - 18" 4 - 16"	— 3 - 24" 4 - 18"	2 - 24" 3 - 18" 4 - 18"	— 3 - 24" 4 - 18"	— — —	
	Order Length	36'	40'	44'	36'	40'	44'	36'	40'	—	
	Max. React. A&C (lbs)	6041	6657	7639	7753	8311	9292	9465	10028	—	
	Max. React. B&D (lbs)	3292	3650	4209	4197	4497	5056	5102	5407	—	
24'	No. of 1 3/4" plies - Beam Depth	2 - 24" 3 - 18" 4 - 16"	— 3 - 24" 4 - 18"	— — —	3 - 24" 4 - 18" —	3 - 24" 4 - 18" —	— — —	— — —	— — —	— — —	
	Order Length	40'	42'	—	40'	42'	—	—	—	—	
	Max. React. A&C (lbs)	7187	7915	—	9211	9875	—	—	—	—	
	Max. React. B&D (lbs)	3915	4336	—	4979	5336	—	—	—	—	

NOTES:

- 2'-0" maximum roof overhang assumed.
- Provide posts or wall at both ends to support reactions. Provide 5" minimum bearing in the direction of the hip or valley at each end based on Douglas Fir-Larch or Southern Pine post or plate material. (For example, a 2x4 wall provides 5" minimum bearing for a hip or valley rafter framing at a 45 degree angle to the wall.)
- The building designer must consider thrust resistant connections at bearing locations.
- For non-equal roof slopes, use the longest horizontal roof rafter span (L) and the greatest roof slope.
- Table is based on triangular loading applied to the hip or valley member. Live load is calculated as applied vertically to the horizontal projection of the rafter and dead load is calculated along the rafter length.
- Size is based on uniform roof snow applications with a load duration factor of 115% and deflection criterion of L/240 live load and L/180 total load.
- Refer to pages 47-48 for fastening recommendations for multiple-ply members. Use the longest horizontal roof rafter span (L) to determine span-carried length for uniform loading.
- Reactions shown include heaviest beam weight selected for load and slope conditions.
- A structural ridge beam is assumed.
- A single 3/2" thick ply can be substituted for any two 1 3/4" thick plies.
- Codes require that hip and valley beam depths be greater than or equal to the cut end of the rafter.

GP LAM® LVL BEARING LENGTH REQUIREMENTS

REACTION (LBS)	SUPPORT MATERIAL															
	SPF SOUTH (335 PSD)				HEM-FIR (405 PSD)				SOUTHERN PINE (565 PSD)				2.OE GP LAM LVL (845 PSD)			
	BEAM THICKNESS				BEAM THICKNESS				BEAM THICKNESS				BEAM THICKNESS			
	1 3/4"	3 1/2"	5 1/4"	7"	1 3/4"	3 1/2"	5 1/4"	7"	1 3/4"	3 1/2"	5 1/4"	7"	1 3/4"	3 1/2"	5 1/4"	7"
1,000	1 3/4"	1 1/2"	1 1/2"	1 1/2"	1 1/2"	1 1/2"	1 1/2"	1 1/2"	1 1/2"	1 1/2"	1 1/2"	1 1/2"	1 1/2"	1 1/2"	1 1/2"	1 1/2"
2,000	3 1/2"	1 3/4"	1 1/2"	1 1/2"	3"	1 1/2"	1 1/2"	1 1/2"	2 1/4"	1 1/2"	1 1/2"	1 1/2"	1 1/2"	1 1/2"	1 1/2"	1 1/2"
3,000	5 1/4"	2 3/4"	1 3/4"	1 1/2"	4 1/4"	2 1/4"	1 1/2"	1 1/2"	3 1/4"	1 3/4"	1 1/2"	1 1/2"	2 1/4"	1 1/2"	1 1/2"	1 1/2"
4,000	7"	3 1/2"	2 1/2"	1 3/4"	5 3/4"	3"	2"	1 1/2"	4 1/4"	2 1/4"	1 1/2"	1 1/2"	2 3/4"	1 1/2"	1 1/2"	1 1/2"
5,000	8 3/4"	4 1/2"	3"	2 1/4"	7 1/4"	3 3/4"	2 1/2"	2"	5 1/4"	2 3/4"	1 3/4"	1 1/2"	3 1/2"	1 3/4"	1 1/2"	1 1/2"
6,000	10 1/4"	5 1/4"	3 1/2"	2 3/4"	8 1/2"	4 1/4"	3"	2 1/4"	6 1/4"	3 1/4"	2 1/4"	1 3/4"	4 1/4"	2 1/4"	1 1/2"	1 1/2"
7,000		6"	4"	3"	10"	5"	3 1/2"	2 1/2"	7 1/4"	3 3/4"	2 1/2"	2"	4 3/4"	2 1/2"	1 3/4"	1 1/2"
8,000		7"	4 3/4"	3 1/2"		5 3/4"	4"	3"	8 1/4"	4 1/4"	2 3/4"	2 1/4"	5 1/2"	2 3/4"	2"	1 1/2"
9,000		7 3/4"	5 1/4"	4"		6 1/2"	4 1/4"	3 3/4"	9 1/4"	4 3/4"	3 1/4"	2 1/2"	6 1/4"	3 1/4"	2 1/4"	1 3/4"
10,000		8 3/4"	5 3/4"	4 1/2"		7 1/4"	4 3/4"	3 3/4"	10 1/4"	5 1/4"	3 1/2"	2 3/4"	7"	3 1/2"	2 1/2"	1 3/4"
11,000		9 1/2"	6 1/2"	4 3/4"		8"	5 1/4"	4"		5 3/4"	3 3/4"	3"	7 1/2"	3 3/4"	2 1/2"	2"
12,000		10 1/4"	7"	5 1/4"		8 1/2"	5 3/4"	4 1/4"		6 1/4"	4 1/4"	3 1/4"	8 1/4"	4 1/4"	2 3/4"	2 1/4"
13,000			7 1/2"	5 3/4"		9 1/4"	6 1/4"	4 3/4"		6 3/4"	4 1/2"	3 1/2"	9"	4 1/2"	3"	2 1/4"
14,000			8"	6"		10"	6 3/4"	5"		7 1/4"	4 3/4"	3 3/4"	9 1/2"	4 3/4"	3 3/4"	2 1/2"
15,000			8 3/4"	6 1/2"			7 1/4"	5 1/2"		7 3/4"	5 1/4"	4"	10 1/4"	5 1/4"	3 1/2"	2 3/4"
16,000			9 1/4"	7"			7 3/4"	5 3/4"		8 1/4"	5 1/2"	4 1/4"		5 1/2"	3 3/4"	2 3/4"
17,000			9 3/4"	7 1/4"			8"	6"		8 3/4"	5 3/4"	4 1/2"		5 3/4"	4"	3"
18,000			10 1/4"	7 3/4"			8 1/2"	6 1/2"		9 1/4"	6 1/4"	4 3/4"		6 1/4"	4 1/4"	3 1/4"
19,000				8 1/4"				9"		9 3/4"	6 1/2"	5"		6 1/2"	4 1/2"	3 1/4"
20,000				8 3/4"				9 1/2"		10 1/4"	6 3/4"	5 1/4"		7"	4 3/4"	3 1/2"
21,000				9"				10"			7 1/4"	5 1/2"		7 1/4"	4 3/4"	3 3/4"
22,000				9 1/2"				10 1/2"			7 1/2"	5 3/4"		7 1/2"	5"	3 3/4"
23,000				10"				8 1/4"			8"	6"		8"	5 1/4"	4"
24,000				10 1/4"				8 1/2"			8 1/4"	6 1/4"		8 1/4"	5 1/2"	4 1/4"
25,000								9"			8 1/2"	6 1/2"		8 1/2"	5 3/4"	4 1/4"

NOTES:

- Minimum required bearing length is 1 1/2" for end bearings and 3" for intermediate bearings.
- Bearing across full width of beam or header is required.
- Table is based on moisture content being less than 16% for engineered lumber and not exceeding 19% for lumber.
- Confirmation of structural adequacy of supporting member is required.
- GP Lam LVL beams and headers must be restrained against rotation at ends and supports.
- When plate material is of **Southern Pine graded non-dense** or of **SPF**, use bearing lengths shown for Hem-Fir .
- When plate material is of **Douglas Fir-Larch** or **Douglas Fir-Larch (N)**, use bearing lengths shown for Southern Pine.
- When GP Lam LVL rests **on steel or in a hanger**, use bearing lengths shown for GP Lam LVL.
- No reduction in bearing length (no increase in bearing stress, $F_{c\perp}$) is allowed for duration of load.
- For non-conforming situations, use FASTBeam® analysis and selection software or contact Georgia-Pacific.

ALLOWABLE HORIZONTAL HOLES IN GP LAM® LVL

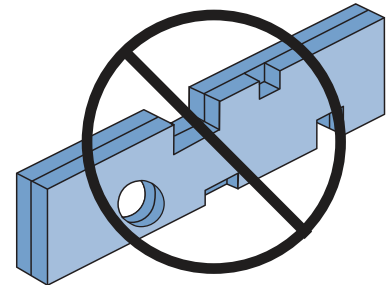
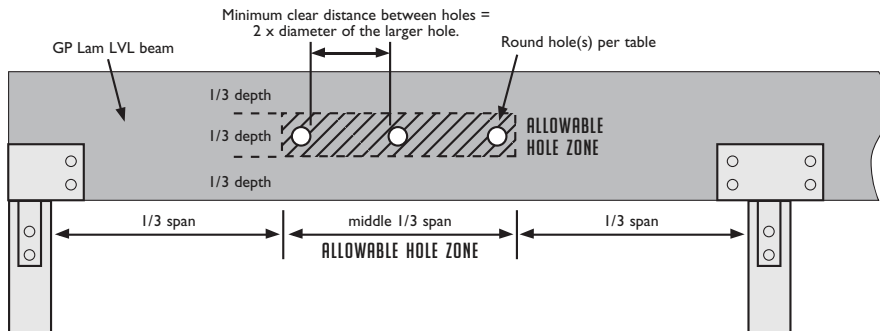

**Do not notch, drill or cut
GP Lam LVL except as shown
in this publication.**

NOTES:

- Hole(s) must be located completely in the allowable hole zone.
- No rectangular holes are allowed.
- No more than three holes allowed per span.
- Table is valid for single and multiple span uniformly loaded beams only. Table is not valid for cantilever sections.
- Hole location, clearance and the effects of beam deflection should be considered to avoid problems with piping.

ALLOWABLE HOLE SIZES

BEAM DEPTH	MAXIMUM ROUND HOLE DIAMETER
3½"-7"	¾"
7¼"-9¼"	1½"
9½"-16"	2"
deeper than 16"	3"

USING ALLOWABLE UNIFORM FLOOR AND ROOF LOAD TABLES (Pages 41-46)

- Tables are based on uniform loads, the more restrictive of simple or continuous spans (measured center-to-center), and dry-use conditions (moisture content less than 16%). Loads shown can be applied to the beam in addition to its own weight. For other loads or span configurations, use FASTBeam® analysis and selection software or contact your Georgia-Pacific representative.
- Beam thickness is the net thickness of the beam. A single 3½" thick ply can be substituted for any two 1¾" thick plies. See pages 47-48 for multiple-ply member connection details.
- To size a beam it is necessary to check both live load and total load. Selected beam must work in both rows. When no live load is shown, total load will control, unless floor live load deflections other than L/360 are checked per note 4.
- For floor live load deflection limits of L/480 or L/600, multiply the value in the floor 'LL' row (or 'TL' when 'LL' is not shown) by 0.75 or 0.60 respectively.
- To size a member for a span not shown, use capacities for the next larger span shown (example: for 7' span, use values shown for 8' span).
- Verify deflection limits with local building code requirements.
- Bearing across full width of beam is assumed.
- Assumes 565 psi bearing stress limited by Douglas Fir, Southern Yellow Pine or other dense supporting material. For SPF or other less dense materials, either double the bearing length shown or refer to Bearing Length Requirements on page 39.
- Bearing length may be adjusted if a beam is not fully loaded. For example, if 4.2" of bearing is required for a beam with maximum total load capacity of 1000 PLF yet the total design load is only 700 PLF the bearing length may be adjusted as follows: $700/1000 \times 4.2 = 2.94"$ minimum (use 2 cripples for 3"). In no case may end bearing length be less than 1½" or intermediate bearing length less than 3".
- Provide lateral support at bearing points, and continuous lateral support along the top (or compression edge) of beam.
- 1¾" thick beams with depth greater than 14" must only be used in multiple-ply members.
- For 3-ply 1¾" (5¼") or 4-ply 1¾" (7") GP Lam LVL, use 1¾" table and multiply by 3 or 4 respectively.
- Roof surface must slope a minimum of ¼/12 or as required for drainage.

EXAMPLE:

Select a 2.0E GP Lam LVL beam to carry 520 PLF live load + 200 PLF dead load. Beam supports both floor and roof, and spans 10'.

When a beam carries floor and roof, use tables for floor loads; these tables are based on more stringent criteria than those used for roof loads. Use the table titled Floor 100%, on pages 41-42. Adding 520 PLF and 200 PLF gives a total load of 720 PLF. Find 10' in the left-most column. To the right are three rows showing Live Load L/360, Total Load and Minimum End and Minimum Interior Bearing requirements in inches. In the row marked Total Load, move to the right to locate a total load of at least 720 PLF. 1¾" x 11⅞" GP Lam LVL Beam can carry 745 PLF total load. Check live load capacity. 1¾" x 11⅞" can carry 629 PLF live load, so live load capacity is also

adequate. Note required end bearing length is 3.8" and 9.5" for interior bearing of multiple spans. (See Note 9 above)

If less bearing length or a depth less than 11⅞" is desired, check the capacity of 3½" LVL beams. In the row marked Total Load, move farther to the right to locate a total load of at least 720 PLF. A 3½" wide x 9¼" deep member can carry 931 PLF total load. Check that live load capacity is at least 520 PLF. 3½" x 9¼" beams can carry 627 PLF, which is sufficient. Use 3½" x 9¼" deep. Required end bearing is 2.4" and 5.9" is required for interior bearing of multiple spans.

ALLOWABLE UNIFORM FLOOR LOADS (PLF) – 100%

(Can be applied to the beam in addition to its own weight.)

2.0E GP LAM® LVL

SPAN	CONDITION	ONE 1 3/4" GP LAM LVL						TWO 1 3/4" GP LAM LVL										
		7 1/2"	9 1/4"	9 1/2"	11 1/4"	11 1/2"	14"	7 1/2"	9 1/4"	9 1/2"	11 1/4"	11 1/2"	14"	16"	18"	24"		
6'	Live Load L/360	660						1319										
	Total Load	763	1028	1063	1325	1425	1575	1526	2056	2126	2649	2849	3151	3149	3147	3141		
	End / Int. Bearing	2.3 / 5.8	3.1 / 7.8	3.2 / 8.1	4.0 / 10.1	4.3 / 10.8	4.8 / 12.0	2.3 / 5.8	3.1 / 7.8	3.2 / 8.1	4.0 / 10.1	4.3 / 10.8	4.8 / 12.0	4.8 / 12.0	4.8 / 12.0	4.8 / 12.0		
8'	Live Load L/360	296	585	629				591	1169	1258								
	Total Load	440	723	746	915	979	1180	880	1446	1492	1831	1958	2360	2358	2356	2350		
	End / Int. Bearing	1.8 / 4.5	2.9 / 7.4	3.0 / 7.6	3.7 / 9.3	4.0 / 10.0	4.8 / 12.0	1.8 / 4.5	2.9 / 7.4	3.0 / 7.6	3.7 / 9.3	4.0 / 10.0	4.8 / 12.0	4.8 / 12.0	4.8 / 12.0	4.8 / 12.0		
10'	Live Load L/360	156	313	338	542	629		312	627	676								
	Total Load	230	466	502	699	745	909	461	931	1005	1084	1258	1398	1490	1818	1883	1881	1876
	End / Int. Bearing	1.5 / 3.0	2.4 / 5.9	2.6 / 6.4	3.6 / 8.9	3.8 / 9.5	4.6 / 11.6	1.5 / 3.0	2.4 / 5.9	2.6 / 6.4	3.6 / 8.9	3.8 / 9.5	4.6 / 11.6	4.8 / 12.0	4.8 / 12.0	4.8 / 12.0	4.8 / 12.0	
11'	Live Load L/360	118	239	258	416	484		236	478	516								
	Total Load	174	354	382	589	652	809	348	708	764	832	967	1305	1618	1711	1709	1703	
	End / Int. Bearing	1.5 / 3.0	2.0 / 5.0	2.2 / 5.4	3.3 / 8.3	3.7 / 9.1	4.5 / 11.3	1.5 / 3.0	2.0 / 5.0	2.2 / 5.4	3.3 / 8.3	3.7 / 9.1	4.5 / 11.3	4.8 / 12.0	4.8 / 12.0	4.8 / 12.0	4.8 / 12.0	
12'	Live Load L/360	91	186	201	325	379		183	372	402								
	Total Load	134	275	297	483	547	728	268	550	594	651	758	1094	1457	1567	1565	1559	
	End / Int. Bearing	1.5 / 3.0	1.7 / 4.2	1.8 / 4.6	3.0 / 7.4	3.4 / 8.4	4.5 / 11.2	1.5 / 3.0	1.7 / 4.2	1.8 / 4.6	3.0 / 7.4	3.4 / 8.4	4.5 / 11.2	4.8 / 12.0	4.8 / 12.0	4.8 / 12.0	4.8 / 12.0	
13'	Live Load L/360	72	147	159	259	302		145	295	319								
	Total Load	105	217	235	384	448	480	211	434	470	519	605	961	1387	1445	1443	1438	
	End / Int. Bearing	1.5 / 3.0	1.5 / 3.6	1.6 / 3.9	2.6 / 6.4	3.0 / 7.5	4.2 / 10.6	1.5 / 3.0	1.5 / 3.6	1.6 / 3.9	2.6 / 6.4	3.0 / 7.5	4.2 / 10.6	4.8 / 12.0	4.8 / 12.0	4.8 / 12.0	4.8 / 12.0	
14'	Live Load L/360	58	119	128	210	245		116	238	257								
	Total Load	84	174	188	309	362	548	168	348	377	420	490	781	1132	1341	1339	1333	
	End / Int. Bearing	1.5 / 3.0	1.5 / 3.2	1.5 / 3.4	2.2 / 5.6	2.6 / 6.5	3.9 / 9.8	1.5 / 3.0	1.5 / 3.2	1.5 / 3.4	2.2 / 5.6	2.6 / 6.5	3.9 / 9.8	4.8 / 12.0	4.8 / 12.0	4.8 / 12.0	4.8 / 12.0	
15'	Live Load L/360	47	97	105	172	201		95	195	210								
	Total Load	68	141	153	253	296	476	136	283	307	344	402	643	935	1228	1249	1243	
	End / Int. Bearing	1.5 / 3.0	1.5 / 3.0	1.5 / 3.0	2.0 / 4.9	2.3 / 5.7	3.7 / 9.1	1.5 / 3.0	1.5 / 3.0	1.5 / 3.0	2.0 / 4.9	2.3 / 5.7	3.7 / 9.1	4.7 / 11.8	4.8 / 12.0	4.8 / 12.0	4.8 / 12.0	
16'	Live Load L/360		80	87	142	167		78	161	174								
	Total Load		116	126	209	245	395	111	233	253	285	334	535	781	1084	1169	1164	
	End / Int. Bearing		1.5 / 3.0	1.5 / 3.0	1.7 / 4.3	2.0 / 5.1	3.2 / 8.1	1.5 / 3.0	1.5 / 3.0	1.5 / 3.0	1.7 / 4.3	2.0 / 5.1	3.2 / 8.1	4.4 / 11.0	4.8 / 12.0	4.8 / 12.0	4.8 / 12.0	
17'	Live Load L/360		67	73	119	140		65	135	146								
	Total Load		97	105	174	204	331	91	194	210	239	280	450	658	916	1094		
	End / Int. Bearing		1.5 / 3.0	1.5 / 3.0	1.5 / 3.9	1.8 / 4.5	2.9 / 7.3	1.5 / 3.0	1.5 / 3.0	1.5 / 3.0	1.5 / 3.9	1.8 / 4.5	2.9 / 7.3	4.2 / 10.4	4.8 / 12.0	4.8 / 12.0		
18'	Live Load L/360		57	61	101	118		55	114	123								
	Total Load		81	88	146	172	280	76	162	176	202	237	382	560	824	781	1038	
	End / Int. Bearing		1.5 / 3.0	1.5 / 3.0	1.5 / 3.5	1.6 / 4.0	2.6 / 6.5	1.5 / 3.0	1.5 / 3.0	1.5 / 3.0	1.5 / 3.5	1.6 / 4.0	2.6 / 6.5	3.8 / 9.6	4.8 / 12.0	4.8 / 12.0	4.8 / 12.0	
19'	Live Load L/360		48	52	86	101		47	97	105								
	Total Load		68	74	124	146	238	64	137	149	173	202	327	480	671	976		
	End / Int. Bearing		1.5 / 3.0	1.5 / 3.0	1.5 / 3.1	1.5 / 3.6	2.4 / 5.9	1.5 / 3.0	1.5 / 3.0	1.5 / 3.0	1.5 / 3.1	1.5 / 3.6	2.4 / 5.9	3.5 / 8.6	4.6 / 11.6	4.8 / 12.0		
20'	Live Load L/360		41	45	74	87		40	83	90								
	Total Load		58	63	106	125	205	54	116	126	148	174	282	414	580	853	926	
	End / Int. Bearing		1.5 / 3.0	1.5 / 3.0	1.5 / 3.0	1.5 / 3.3	2.1 / 5.3	1.5 / 3.0	1.5 / 3.0	1.5 / 3.0	1.5 / 3.0	1.5 / 3.3	2.1 / 5.3	3.1 / 7.9	4.4 / 11.0	4.8 / 12.0		
22'	Live Load L/360				56	65		63	68									
	Total Load				79	93	153	85	93	112	131	213	315	442	840			
	End / Int. Bearing				1.5 / 3.0	1.5 / 3.0	1.8 / 4.5	1.5 / 3.0	1.5 / 3.0	1.5 / 3.0	1.5 / 3.0	1.8 / 4.5	2.6 / 6.6	3.7 / 9.2	4.8 / 12.0			
24'	Live Load L/360				43	51		48	52									
	Total Load				60	71	117	64	70	87	102	165	244	344	768			
	End / Int. Bearing				1.5 / 3.0	1.5 / 3.0	1.5 / 3.8	1.5 / 3.0	1.5 / 3.0	1.5 / 3.0	1.5 / 3.0	1.5 / 3.8	2.2 / 5.6	3.1 / 7.8	4.8 / 12.0			
26'	Live Load L/360					40				41								
	Total Load					54	65			53	68	80	131	193	273	623		
	End / Int. Bearing					1.5 / 3.0	1.5 / 3.2			1.5 / 3.0	1.5 / 3.0	1.5 / 3.0	1.5 / 3.2	1.9 / 4.8	2.7 / 6.7	4.8 / 12.0		
28'	Live Load L/360						52											
	Total Load						72			55	64	105	156	220	505			
	End / Int. Bearing						1.5 / 3.0			1.5 / 3.0	1.5 / 3.0	1.5 / 3.0	1.7 / 4.1	2.3 / 5.8	4.8 / 12.0			

KEY TO TABLES

Live Load L/360 = Maximum live load — limits deflection to L/360

Total Load = Maximum total load — limits deflection to L/240

End / Int. Bearing = Required minimum end bearing (inches) for simple or multiple span beams and minimum interior bearing (inches) for multiple span beams based on plate bearing stress of 565 psi.

See "Using Allowable Uniform Floor and Roof Load Tables," page 40.

ALLOWABLE UNIFORM FLOOR LOADS (PLF) – 100%

(Can be applied to the beam in addition to its own weight.)

2.0E GP LAM® LVL

SPAN	CONDITION	THREE 1 3/4" GP LAM LVL								FOUR 1 3/4" GP LAM LVL							
		9"	9 1/2"	11"	11 1/2"	14"	16"	18"	24"	9"	9 1/2"	11"	11 1/2"	14"	16"	18"	24"
6'	Live Load L/360																
	Total Load	3084	3190	3974	4274	4726	4723	4720	4712	4112	4253	5299	5699	6301	6298	6294	6283
	End / Int. Bearing	3.1 / 7.8	3.2 / 8.1	4.0 / 10.1	4.3 / 10.8	4.8 / 12.0	4.8 / 12.0	4.8 / 12.0	4.8 / 12.0	4.8 / 12.0	3.1 / 7.8	3.2 / 8.1	4.0 / 10.1	4.3 / 10.8	4.8 / 12.0	4.8 / 12.0	4.8 / 12.0
8'	Live Load L/360																
	Total Load	1754	1887	2746	2937	3540	3537	3534	3525	2338	2516	3662	3916	4719	4716	4712	4701
	End / Int. Bearing	2.9 / 7.4	3.0 / 7.6	3.7 / 9.3	4.0 / 10.0	4.8 / 12.0	4.8 / 12.0	4.8 / 12.0	4.8 / 12.0	2.9 / 7.4	3.0 / 7.6	3.7 / 9.3	4.0 / 10.0	4.8 / 12.0	4.8 / 12.0	4.8 / 12.0	4.8 / 12.0
10'	Live Load L/360																
	Total Load	1397	1507	2096	2235	2727	2825	2822	2813	1254	1352	2168	2516	2980	3636	3766	3751
	End / Int. Bearing	2.4 / 5.9	2.6 / 6.4	3.6 / 8.9	3.8 / 9.5	4.6 / 11.6	4.8 / 12.0	4.8 / 12.0	4.8 / 12.0	2.4 / 5.9	2.6 / 6.4	3.6 / 8.9	3.8 / 9.5	4.6 / 11.6	4.8 / 12.0	4.8 / 12.0	4.8 / 12.0
11'	Live Load L/360																
	Total Load	1397	1507	2096	2235	2727	2825	2822	2813	1254	1352	2168	2516	2980	3636	3766	3751
	End / Int. Bearing	2.0 / 5.0	2.2 / 5.4	3.3 / 8.3	3.7 / 9.1	4.5 / 11.3	4.8 / 12.0	4.8 / 12.0	4.8 / 12.0	2.0 / 5.0	2.2 / 5.4	3.3 / 8.3	3.7 / 9.1	4.5 / 11.3	4.8 / 12.0	4.8 / 12.0	4.8 / 12.0
12'	Live Load L/360																
	Total Load	1397	1507	2096	2235	2727	2825	2822	2813	1254	1352	2168	2516	2980	3636	3766	3751
	End / Int. Bearing	1.7 / 4.2	1.8 / 4.6	3.0 / 7.4	3.4 / 8.4	4.5 / 11.2	4.8 / 12.0	4.8 / 12.0	4.8 / 12.0	1.7 / 4.2	1.8 / 4.6	3.0 / 7.4	3.4 / 8.4	4.5 / 11.2	4.8 / 12.0	4.8 / 12.0	4.8 / 12.0
13'	Live Load L/360																
	Total Load	1397	1507	2096	2235	2727	2825	2822	2813	1254	1352	2168	2516	2980	3636	3766	3751
	End / Int. Bearing	1.5 / 3.6	1.6 / 3.9	2.6 / 6.4	3.0 / 7.5	4.2 / 10.6	4.8 / 12.0	4.8 / 12.0	4.8 / 12.0	1.5 / 3.6	1.6 / 3.9	2.6 / 6.4	3.0 / 7.5	4.2 / 10.6	4.8 / 12.0	4.8 / 12.0	4.8 / 12.0
14'	Live Load L/360																
	Total Load	1397	1507	2096	2235	2727	2825	2822	2813	1254	1352	2168	2516	2980	3636	3766	3751
	End / Int. Bearing	1.5 / 3.2	1.5 / 3.4	2.2 / 5.6	2.6 / 6.5	3.9 / 9.8	4.8 / 12.0	4.8 / 12.0	4.8 / 12.0	1.5 / 3.2	1.5 / 3.4	2.2 / 5.6	2.6 / 6.5	3.9 / 9.8	4.8 / 12.0	4.8 / 12.0	4.8 / 12.0
15'	Live Load L/360																
	Total Load	1397	1507	2096	2235	2727	2825	2822	2813	1254	1352	2168	2516	2980	3636	3766	3751
	End / Int. Bearing	1.5 / 3.0	1.5 / 3.0	2.0 / 4.9	2.3 / 5.7	3.7 / 9.1	4.7 / 11.8	4.8 / 12.0	4.8 / 12.0	1.5 / 3.0	1.5 / 3.0	2.0 / 4.9	2.3 / 5.7	3.7 / 9.1	4.7 / 11.8	4.8 / 12.0	4.8 / 12.0
16'	Live Load L/360																
	Total Load	1397	1507	2096	2235	2727	2825	2822	2813	1254	1352	2168	2516	2980	3636	3766	3751
	End / Int. Bearing	1.5 / 3.0	1.5 / 3.0	1.7 / 4.3	2.0 / 5.1	3.2 / 8.1	4.4 / 11.0	4.8 / 12.0	4.8 / 12.0	1.5 / 3.0	1.5 / 3.0	1.7 / 4.3	2.0 / 5.1	3.2 / 8.1	4.4 / 11.0	4.8 / 12.0	4.8 / 12.0
17'	Live Load L/360																
	Total Load	1397	1507	2096	2235	2727	2825	2822	2813	1254	1352	2168	2516	2980	3636	3766	3751
	End / Int. Bearing	1.5 / 3.0	1.5 / 3.0	1.5 / 3.9	1.8 / 4.5	2.9 / 7.3	4.2 / 10.4	4.8 / 12.0	4.8 / 12.0	1.5 / 3.0	1.5 / 3.0	1.5 / 3.9	1.8 / 4.5	2.9 / 7.3	4.2 / 10.4	4.8 / 12.0	4.8 / 12.0
18'	Live Load L/360																
	Total Load	1397	1507	2096	2235	2727	2825	2822	2813	1254	1352	2168	2516	2980	3636	3766	3751
	End / Int. Bearing	1.5 / 3.0	1.5 / 3.0	1.5 / 3.5	1.6 / 4.0	2.6 / 6.5	3.8 / 9.6	4.8 / 12.0	4.8 / 12.0	1.5 / 3.0	1.5 / 3.0	1.5 / 3.5	1.6 / 4.0	2.6 / 6.5	3.8 / 9.6	4.8 / 12.0	4.8 / 12.0
19'	Live Load L/360																
	Total Load	1397	1507	2096	2235	2727	2825	2822	2813	1254	1352	2168	2516	2980	3636	3766	3751
	End / Int. Bearing	1.5 / 3.0	1.5 / 3.0	1.5 / 3.1	1.5 / 3.6	2.4 / 5.9	3.5 / 8.6	4.6 / 11.6	4.8 / 12.0	1.5 / 3.0	1.5 / 3.0	1.5 / 3.1	1.5 / 3.6	2.4 / 5.9	3.5 / 8.6	4.6 / 11.6	4.8 / 12.0
20'	Live Load L/360																
	Total Load	1397	1507	2096	2235	2727	2825	2822	2813	1254	1352	2168	2516	2980	3636	3766	3751
	End / Int. Bearing	1.5 / 3.0	1.5 / 3.0	1.5 / 3.0	1.5 / 3.3	2.1 / 5.3	3.1 / 7.9	4.4 / 11.0	4.8 / 12.0	1.5 / 3.0	1.5 / 3.0	1.5 / 3.0	1.5 / 3.3	2.1 / 5.3	3.1 / 7.9	4.4 / 11.0	4.8 / 12.0
22'	Live Load L/360																
	Total Load	1397	1507	2096	2235	2727	2825	2822	2813	1254	1352	2168	2516	2980	3636	3766	3751
	End / Int. Bearing	1.5 / 3.0	1.5 / 3.0	1.5 / 3.0	1.5 / 3.0	1.8 / 4.5	2.6 / 6.6	3.7 / 9.2	4.8 / 12.0	1.5 / 3.0	1.5 / 3.0	1.5 / 3.0	1.5 / 3.0	1.8 / 4.5	2.6 / 6.6	3.7 / 9.2	4.8 / 12.0
24'	Live Load L/360																
	Total Load	1397	1507	2096	2235	2727	2825	2822	2813	1254	1352	2168	2516	2980	3636	3766	3751
	End / Int. Bearing	1.5 / 3.0	1.5 / 3.0	1.5 / 3.0	1.5 / 3.0	1.5 / 3.8	2.2 / 5.6	3.1 / 7.8	4.8 / 12.0	1.5 / 3.0	1.5 / 3.0	1.5 / 3.0	1.5 / 3.0	1.5 / 3.8	2.2 / 5.6	3.1 / 7.8	4.8 / 12.0
26'	Live Load L/360																
	Total Load	1397	1507	2096	2235	2727	2825	2822	2813	1254	1352	2168	2516	2980	3636	3766	3751
	End / Int. Bearing	1.5 / 3.0	1.5 / 3.0	1.5 / 3.0	1.5 / 3.0	1.5 / 3.2	1.9 / 4.8	2.7 / 6.7	4.8 / 12.0	1.5 / 3.0	1.5 / 3.0	1.5 / 3.0	1.5 / 3.0	1.5 / 3.2	1.9 / 4.8	2.7 / 6.7	4.8 / 12.0
28'	Live Load L/360																
	Total Load	1397	1507	2096	2235	2727	2825	2822	2813	1254	1352	2168	2516	2980	3636	3766	3751
	End / Int. Bearing	1.5 / 3.0	1.5 / 3.0	1.5 / 3.0	1.5 / 3.0	1.5 / 3.0	1.7 / 4.1	2.3 / 5.8	4.8 / 12.0	1.5 / 3.0	1.5 / 3.0	1.5 / 3.0	1.5 / 3.0	1.5 / 3.0	1.7 / 4.1	2.3 / 5.8	4.8 / 12.0

KEY TO TABLES

Live Load L/360 = Maximum live load — limits deflection to L/360

Total Load = Maximum total load — limits deflection to L/240

End / Int. Bearing = Required minimum end bearing (inches) for simple or multiple span beams and minimum interior bearing (inches) for multiple span beams based on plate bearing stress of 565 psi.

See "Using Allowable Uniform Floor and Roof Load Tables," page 40.

ALLOWABLE UNIFORM ROOF LOADS (PLF) – 115% (SNOW)

(Can be applied to the beam in addition to its own weight.)

2.0E GP LAM® LVL

SPAN	CONDITION	ONE 1 1/4" GP LAM LVL						TWO 1 1/4" GP LAM LVL								
		7 1/4"	9 1/4"	9 1/2"	11 1/4"	11 1/2"	14"	7 1/4"	9 1/4"	9 1/2"	11 1/4"	11 1/2"	14"	16"	18"	24"
6'	Live Load L/240	878	1183	1223	1524	1576	1575	1756	2366	2447	3048	3153	3151	3149	3147	3141
	Total Load	2.7 / 6.7	3.6 / 9.0	3.7 / 9.3	4.6 / 11.6	4.8 / 12.0	4.8 / 12.0	2.7 / 6.7	3.6 / 9.0	3.7 / 9.3	4.6 / 11.6	4.8 / 12.0	4.8 / 12.0	4.8 / 12.0	4.8 / 12.0	4.8 / 12.0
8'	Live Load L/240	444	832	859	1054	1127	1180	887	1664	1717	2107	2253	2360	2358	2356	2350
	Total Load	2.3 / 5.7	3.4 / 8.5	3.5 / 8.7	4.3 / 10.7	4.6 / 11.5	4.8 / 12.0	2.3 / 5.7	3.4 / 8.5	3.5 / 8.7	4.3 / 10.7	4.6 / 11.5	4.8 / 12.0	4.8 / 12.0	4.8 / 12.0	4.8 / 12.0
10'	Live Load L/240	234	470	507	804	858	943	468	940	1014	1609	1715	1885	1883	1881	1876
	Total Load	1.6 / 3.9	2.9 / 7.2	3.0 / 7.6	4.1 / 10.2	4.4 / 10.9	4.8 / 12.0	1.6 / 3.9	2.9 / 7.2	3.0 / 7.6	4.1 / 10.2	4.4 / 10.9	4.8 / 12.0	4.8 / 12.0	4.8 / 12.0	4.8 / 12.0
11'	Live Load L/240	177	358	387	624	725	784	355	717	773	1248	1451	1569	1567	1565	1559
	Total Load	1.5 / 3.3	2.6 / 6.6	2.8 / 6.9	3.8 / 9.5	4.2 / 10.5	4.8 / 12.0	1.5 / 3.3	2.6 / 6.6	2.8 / 6.9	3.8 / 9.5	4.2 / 10.5	4.8 / 12.0	4.8 / 12.0	4.8 / 12.0	4.8 / 12.0
12'	Live Load L/240	137	279	301	488	569	784	275	558	603	977	1137	1260	1567	1565	1559
	Total Load	1.5 / 3.0	2.3 / 5.6	2.4 / 6.1	3.5 / 8.7	3.9 / 9.6	4.8 / 12.0	1.5 / 3.0	2.3 / 5.6	2.4 / 6.1	3.5 / 8.7	3.9 / 9.6	4.8 / 12.0	4.8 / 12.0	4.8 / 12.0	4.8 / 12.0
13'	Live Load L/240	109	221	239	389	454	720	218	443	479	778	907	1441	1445	1443	1438
	Total Load	1.5 / 3.0	1.9 / 4.9	2.1 / 5.2	3.2 / 8.0	3.6 / 8.9	4.8 / 12.0	1.5 / 3.0	1.9 / 4.9	2.1 / 5.2	3.2 / 8.0	3.6 / 8.9	4.8 / 12.0	4.8 / 12.0	4.8 / 12.0	4.8 / 12.0
14'	Live Load L/240	87	179	193	315	367	586	175	357	386	629	735	1171	1341	1339	1333
	Total Load	1.5 / 3.0	1.7 / 4.2	1.8 / 4.6	3.0 / 7.4	3.3 / 8.3	4.5 / 11.3	1.5 / 3.0	1.7 / 4.2	1.8 / 4.6	3.0 / 7.4	3.3 / 8.3	4.5 / 11.3	4.8 / 12.0	4.8 / 12.0	4.8 / 12.0
15'	Live Load L/240	71	146	158	258	301	482	143	292	316	516	603	964	1250	1249	1243
	Total Load	1.5 / 3.0	1.5 / 3.7	1.6 / 4.0	2.6 / 6.5	3.0 / 7.6	4.2 / 10.5	1.5 / 3.0	1.5 / 3.7	1.6 / 4.0	2.6 / 6.5	3.0 / 7.6	4.2 / 10.5	4.8 / 12.0	4.8 / 12.0	4.8 / 12.0
16'	Live Load L/240	59	121	131	214	250	401	118	242	262	428	501	803	1171	1169	1164
	Total Load	1.5 / 3.0	1.5 / 3.3	1.5 / 3.5	2.3 / 5.8	2.7 / 6.2	3.9 / 9.9	1.5 / 3.0	1.5 / 3.3	1.5 / 3.5	2.3 / 5.8	2.7 / 6.7	3.9 / 9.9	4.8 / 12.0	4.8 / 12.0	4.8 / 12.0
17'	Live Load L/240	49	101	109	179	210	338	98	202	219	359	420	675	987	1100	1094
	Total Load	1.5 / 3.0	1.5 / 3.0	1.5 / 3.1	2.1 / 5.1	2.4 / 6.0	3.7 / 9.3	1.5 / 3.0	1.5 / 3.0	1.5 / 3.1	2.1 / 5.1	2.4 / 6.0	3.7 / 9.3	4.8 / 12.0	4.8 / 12.0	4.8 / 12.0
18'	Live Load L/240	41	85	92	152	178	286	83	171	185	304	356	573	840	1038	1032
	Total Load	1.5 / 3.0	1.5 / 3.0	1.5 / 3.0	1.8 / 4.6	2.2 / 5.4	3.5 / 8.7	1.5 / 3.0	1.5 / 3.0	1.5 / 3.0	1.8 / 4.6	2.2 / 5.4	3.5 / 8.7	4.5 / 11.3	4.8 / 12.0	4.8 / 12.0
19'	Live Load L/240	73	79	129	152	245	71	146	158	259	304	490	720	982	976	
	Total Load	1.5 / 3.0	1.5 / 3.0	1.7 / 4.2	1.9 / 4.9	3.1 / 7.8	1.5 / 3.0	1.5 / 3.0	1.5 / 3.0	1.7 / 4.2	1.9 / 4.9	3.1 / 7.8	4.3 / 10.7	4.8 / 12.0	4.8 / 12.0	
20'	Live Load L/240	62	67	111	131	211	61	125	135	223	262	423	621	870	926	
	Total Load	1.5 / 3.0	1.5 / 3.0	1.5 / 3.8	1.8 / 4.4	2.8 / 7.1	1.5 / 3.0	1.5 / 3.0	1.5 / 3.0	1.5 / 3.8	1.8 / 4.4	2.8 / 7.1	4.1 / 10.2	4.8 / 12.0	4.8 / 12.0	
22'	Live Load L/240	47	51	84	99	160	45	94	102	168	198	320	472	663	840	
	Total Load	1.5 / 3.0	1.5 / 3.0	1.5 / 3.1	1.5 / 3.7	2.4 / 5.9	1.5 / 3.0	1.5 / 3.0	1.5 / 3.0	1.5 / 3.1	1.5 / 3.7	2.4 / 5.9	3.5 / 8.8	4.6 / 11.5	4.8 / 12.0	
24'	Live Load L/240	39	65	76	124	159	73	79	130	153	248	367	516	768		
	Total Load	1.5 / 3.0	1.5 / 3.0	1.5 / 3.1	2.0 / 5.0	1.5 / 3.0	1.5 / 3.0	1.5 / 3.0	1.5 / 3.0	1.5 / 3.1	2.0 / 5.0	3.0 / 7.4	4.2 / 10.4	4.8 / 12.0		
26'	Live Load L/240	51	60	98	124	159	57	62	103	121	196	290	409	707		
	Total Load	1.5 / 3.0	1.5 / 3.0	1.7 / 4.3	1.5 / 3.0	1.5 / 3.0	1.5 / 3.0	1.5 / 3.0	1.5 / 3.0	1.5 / 3.0	1.7 / 4.3	2.5 / 6.4	3.6 / 9.0	4.8 / 12.0		
28'	Live Load L/240	41	48	79	98	124	46	50	82	97	158	234	330	655		
	Total Load	1.5 / 3.0	1.5 / 3.0	1.5 / 3.7	1.5 / 3.0	1.5 / 3.0	1.5 / 3.0	1.5 / 3.0	1.5 / 3.0	1.5 / 3.0	1.5 / 3.7	2.2 / 5.5	3.1 / 7.8	4.8 / 12.0		

KEY TO TABLES

Live Load L/240 = Maximum live load — limits deflection to L/240

Total Load = Maximum total load — limits deflection to L/180

End / Int. Bearing = Required minimum end bearing (inches) for simple or multiple span beams and minimum interior bearing (inches) for multiple span beams based on plate bearing stress of 565 psi.

See "Using Allowable Uniform Floor and Roof Load Tables," page 40.

ALLOWABLE UNIFORM ROOF LOADS (PLF) – 115% (SNOW)

(Can be applied to the beam in addition to its own weight.)

2.0E GP LAM® LVL

SPAN	CONDITION	THREE 1 3/4" GP LAM LVL								FOUR 1 3/4" GP LAM LVL							
		9"	9 1/2"	11"	11 1/2"	14"	16"	18"	24"	9"	9 1/2"	11"	11 1/2"	14"	16"	18"	24"
6'	Live Load L/240	3549	3670	4573	4729	4726	4723	4720	4712	4731	4894	6097	6305	6301	6298	6294	6283
	Total Load	3.6 / 9.0	3.7 / 9.3	4.6 / 11.6	4.8 / 12.0	4.8 / 12.0	4.8 / 12.0	4.8 / 12.0	4.8 / 12.0	3.6 / 9.0	3.7 / 9.3	4.6 / 11.6	4.8 / 12.0	4.8 / 12.0	4.8 / 12.0	4.8 / 12.0	4.8 / 12.0
	End / Int. Bearing																
8'	Live Load L/240	2496	2576	3161	3380	3540	3537	3534	3525	3328	3435	4214	4506	4719	4716	4712	4701
	Total Load	3.4 / 8.5	3.5 / 8.7	4.3 / 10.7	4.6 / 11.5	4.8 / 12.0	4.8 / 12.0	4.8 / 12.0	4.8 / 12.0	3.4 / 8.5	3.5 / 8.7	4.3 / 10.7	4.6 / 11.5	4.8 / 12.0	4.8 / 12.0	4.8 / 12.0	4.8 / 12.0
	End / Int. Bearing																
10'	Live Load L/240	1410	1521	2413	2573	2828	2825	2822	2813	1880	2028	3218	3430	3770	3766	3763	3751
	Total Load	1700	1788	2413	2573	2828	2825	2822	2813	2267	2385	3218	3430	3770	3766	3763	3751
	End / Int. Bearing	2.9 / 7.2	3.0 / 7.6	4.1 / 10.2	4.4 / 10.9	4.8 / 12.0	4.8 / 12.0	4.8 / 12.0	4.8 / 12.0	2.9 / 7.2	3.0 / 7.6	4.1 / 10.2	4.4 / 10.9	4.8 / 12.0	4.8 / 12.0	4.8 / 12.0	4.8 / 12.0
11'	Live Load L/240	1075	1160	1871	2176	2569	2566	2563	2555	1434	1547	2495	2901	3004	3425	3421	3418
	Total Load	1403	1476	2033	2253	2569	2566	2563	2555	1870	1968	2711	3004	3425	3421	3418	3406
	End / Int. Bearing	2.6 / 6.6	2.8 / 6.9	3.8 / 9.5	4.2 / 10.5	4.8 / 12.0	4.8 / 12.0	4.8 / 12.0	4.8 / 12.0	2.6 / 6.6	2.8 / 6.9	3.8 / 9.5	4.2 / 10.5	4.8 / 12.0	4.8 / 12.0	4.8 / 12.0	4.8 / 12.0
12'	Live Load L/240	838	904	1465	1706	2353	2350	2347	2339	1117	1206	1953	2275	3137	3134	3130	3119
	Total Load	1104	1192	1706	1890	2353	2350	2347	2339	1471	1590	2275	2521	3137	3134	3130	3119
	End / Int. Bearing	2.3 / 5.6	2.4 / 6.1	3.5 / 8.7	3.9 / 9.6	4.8 / 12.0	4.8 / 12.0	4.8 / 12.0	4.8 / 12.0	2.3 / 5.6	2.4 / 6.1	3.5 / 8.7	3.9 / 9.6	4.8 / 12.0	4.8 / 12.0	4.8 / 12.0	4.8 / 12.0
13'	Live Load L/240	665	718	1167	1361	2161	2161	2161	2161	886	957	1556	1815	2882	2882	2882	2875
	Total Load	873	944	1451	1608	2161	2161	2161	2161	1164	1258	1935	2144	2894	2890	2886	2875
	End / Int. Bearing	1.9 / 4.9	2.1 / 5.2	3.2 / 8.0	3.6 / 8.9	4.8 / 12.0	4.8 / 12.0	4.8 / 12.0	4.8 / 12.0	1.9 / 4.9	2.1 / 5.2	3.2 / 8.0	3.6 / 8.9	4.8 / 12.0	4.8 / 12.0	4.8 / 12.0	4.8 / 12.0
14'	Live Load L/240	536	579	944	1102	1757	1757	1757	1757	715	772	1259	1469	2343	2343	2339	2328
	Total Load	701	759	1243	1384	1892	2011	2008	2000	935	1012	1657	1846	2523	2682	2678	2667
	End / Int. Bearing	1.7 / 4.2	1.8 / 4.6	3.0 / 7.4	3.3 / 8.3	4.5 / 11.3	4.8 / 12.0	4.8 / 12.0	4.8 / 12.0	1.7 / 4.2	1.8 / 4.6	3.0 / 7.4	3.3 / 8.3	4.5 / 11.3	4.8 / 12.0	4.8 / 12.0	4.8 / 12.0
15'	Live Load L/240	438	474	774	904	1446	1446	1446	1446	584	632	1032	1206	1929	1929	1929	1929
	Total Load	571	618	1016	1189	1646	1876	1873	1864	761	824	1354	1585	2195	2501	2497	2486
	End / Int. Bearing	1.5 / 3.7	1.6 / 4.0	2.6 / 6.5	3.0 / 7.6	4.2 / 10.5	4.8 / 12.0	4.8 / 12.0	4.8 / 12.0	1.5 / 3.7	1.6 / 4.0	2.6 / 6.5	3.0 / 7.6	4.2 / 10.5	4.8 / 12.0	4.8 / 12.0	4.8 / 12.0
16'	Live Load L/240	363	392	642	751	1204	1204	1204	1204	484	523	856	1001	1606	1606	1606	1606
	Total Load	471	510	840	984	1444	1757	1754	1746	627	679	1120	1312	1926	2343	2339	2328
	End / Int. Bearing	1.5 / 3.3	1.5 / 3.5	2.3 / 5.8	2.7 / 6.7	3.9 / 9.9	4.8 / 12.0	4.8 / 12.0	4.8 / 12.0	1.5 / 3.3	1.5 / 3.5	2.3 / 5.8	2.7 / 6.7	3.9 / 9.9	4.8 / 12.0	4.8 / 12.0	4.8 / 12.0
17'	Live Load L/240	304	328	538	630	1013	1481	1481	1481	405	438	718	840	1350	1350	1350	1350
	Total Load	392	424	702	823	1277	1646	1649	1641	522	566	936	1097	1703	2195	2199	2188
	End / Int. Bearing	1.5 / 3.0	1.5 / 3.1	2.1 / 5.1	2.4 / 6.0	3.7 / 9.3	4.8 / 12.0	4.8 / 12.0	4.8 / 12.0	1.5 / 3.0	1.5 / 3.1	2.1 / 5.1	2.4 / 6.0	3.7 / 9.3	4.8 / 12.0	4.8 / 12.0	4.8 / 12.0
18'	Live Load L/240	257	278	456	534	859	1259	1259	1259	342	370	608	711	1146	1679	1679	1679
	Total Load	329	357	592	695	1126	1466	1556	1548	439	476	789	926	1501	1955	2075	2064
	End / Int. Bearing	1.5 / 3.0	1.5 / 3.0	1.8 / 4.6	2.2 / 5.4	3.5 / 8.7	4.5 / 11.3	4.8 / 12.0	4.8 / 12.0	1.5 / 3.0	1.5 / 3.0	1.8 / 4.6	2.2 / 5.4	3.5 / 8.7	4.5 / 11.3	4.8 / 12.0	4.8 / 12.0
19'	Live Load L/240	219	237	389	456	735	1080	1080	1080	292	316	519	608	980	1439	1439	1439
	Total Load	279	302	503	591	961	1313	1473	1465	372	403	670	788	1281	1751	1964	1953
	End / Int. Bearing	1.5 / 3.0	1.5 / 3.0	1.7 / 4.2	1.9 / 4.9	3.1 / 7.8	4.3 / 10.7	4.8 / 12.0	4.8 / 12.0	1.5 / 3.0	1.5 / 3.0	1.7 / 4.2	1.9 / 4.9	3.1 / 7.8	4.3 / 10.7	4.8 / 12.0	4.8 / 12.0
20'	Live Load L/240	188	203	335	392	634	932	1305	1305	251	271	446	523	845	1243	1740	1740
	Total Load	238	258	430	506	825	1183	1398	1390	317	344	574	675	1100	1578	1864	1853
	End / Int. Bearing	1.5 / 3.0	1.5 / 3.0	1.5 / 3.8	1.8 / 4.4	2.8 / 7.1	4.1 / 10.2	4.8 / 12.0	4.8 / 12.0	1.5 / 3.0	1.5 / 3.0	1.5 / 3.8	1.8 / 4.4	2.8 / 7.1	4.1 / 10.2	4.8 / 12.0	4.8 / 12.0
22'	Live Load L/240	142	153	253	297	480	708	994	994	189	205	337	395	640	944	1325	1325
	Total Load	176	191	321	379	621	921	1219	1260	235	255	428	505	827	1228	1626	1680
	End / Int. Bearing	1.5 / 3.0	1.5 / 3.0	1.5 / 3.1	1.5 / 3.7	2.4 / 5.9	3.5 / 8.8	4.6 / 11.5	4.8 / 12.0	1.5 / 3.0	1.5 / 3.0	1.5 / 3.1	1.5 / 3.7	2.4 / 5.9	3.5 / 8.8	4.6 / 11.5	4.8 / 12.0
24'	Live Load L/240	109	118	196	230	372	550	774	774	146	158	261	306	497	733	1032	1032
	Total Load	133	145	245	289	477	711	1006	1152	177	193	327	386	636	948	1342	1537
	End / Int. Bearing	1.5 / 3.0	1.5 / 3.0	1.5 / 3.0	1.5 / 3.1	2.0 / 5.0	3.0 / 7.4	4.2 / 10.4	4.8 / 12.0	1.5 / 3.0	1.5 / 3.0	1.5 / 3.0	1.5 / 3.1	2.0 / 5.0	3.0 / 7.4	4.2 / 10.4	4.8 / 12.0
26'	Live Load L/240	86	93	154	181	294	436	614	614	115	124	206	242	393	581	818	818
	Total Load	102	111	190	225	373	558	793	1061	136	148	253	300	497	744	1057	1415
	End / Int. Bearing	1.5 / 3.0	1.5 / 3.0	1.5 / 3.0	1.5 / 3.0	1.7 / 4.3	2.5 / 6.4	3.6 / 9.0	4.8 / 12.0	1.5 / 3.0	1.5 / 3.0	1.5 / 3.0	1.5 / 3.0	1.7 / 4.3	2.5 / 6.4	3.6 / 9.0	4.8 / 12.0
28'	Live Load L/240	69	75	124	145	237	351	495	495	92	100	165	194	316	467	660	660
	Total Load	79	86	149	177	296	445	634	983	105	115	199	236	394	593	845	1311
	End / Int. Bearing	1.5 / 3.0	1.5 / 3.0	1.5 / 3.0	1.5 / 3.0	1.5 / 3.7	2.2 / 5.5	3.1 / 7.8	4.8 / 12.0	1.5 / 3.0	1.5 / 3.0	1.5 / 3.0	1.5 / 3.0	1.5 / 3.7	2.2 / 5.5	3.1 / 7.8	4.8 / 12.0

KEY TO TABLES

Live Load L/240 = Maximum live load — limits deflection to L/240

Total Load = Maximum total load — limits deflection to L/180

End / Int. Bearing = Required minimum end bearing (inches) for simple or multiple span beams and minimum interior bearing (inches) for multiple span beams based on plate bearing stress of 565 psi.

See "Using Allowable Uniform Floor and Roof Load Tables," page 40.

ALLOWABLE UNIFORM ROOF LOADS (PLF) – 125% (NON-SNOW)

(Can be applied to the beam in addition to its own weight.)

2.0E GP LAM® LVL

SPAN	CONDITION	ONE 1 3/4" GP LAM LVL						TWO 1 3/4" GP LAM LVL									
		7 1/2"	9 1/4"	9 1/2"	11 1/4"	11 1/2"	14"	7 1/2"	9 1/4"	9 1/2"	11 1/4"	11 1/2"	14"	16"	18"	24"	
6'	Live Load L/240	954	1286	1330	1577	1576	1575	1909	2572	2660	3153	3153	3151	3149	3147	3141	
	Total Load	954	1286	1330	1577	1576	1575	1909	2572	2660	3153	3153	3151	3149	3147	3141	
	End / Int. Bearing	2.9 / 7.3	3.9 / 9.8	4.0 / 10.1	4.8 / 12.0	4.8 / 12.0	4.8 / 12.0	2.9 / 7.3	3.9 / 9.8	4.0 / 10.1	4.8 / 12.0	4.8 / 12.0	4.8 / 12.0	4.8 / 12.0	4.8 / 12.0	4.8 / 12.0	
8'	Live Load L/240	444	877					887	1754								
	Total Load	588	905	934	1146	1181	1180	1176	1809	1867	2291	2362	2360	2358	2356	2350	
	End / Int. Bearing	2.4 / 6.0	3.7 / 9.2	3.8 / 9.5	4.7 / 11.6	4.8 / 12.0	4.8 / 12.0	2.4 / 6.0	3.7 / 9.2	3.8 / 9.5	4.7 / 11.6	4.8 / 12.0	4.8 / 12.0	4.8 / 12.0	4.8 / 12.0	4.8 / 12.0	
10'	Live Load L/240	234	470	507	813			468	940	1014	1626						
	Total Load	308	616	648	875	933	943	617	1233	1297	1750	1865	1885	1883	1881	1876	
	End / Int. Bearing	1.6 / 3.9	3.1 / 7.8	3.3 / 8.3	4.5 / 11.1	4.7 / 11.9	4.8 / 12.0	1.6 / 3.9	3.1 / 7.8	3.3 / 8.3	4.5 / 11.1	4.7 / 11.9	4.8 / 12.0	4.8 / 12.0	4.8 / 12.0	4.8 / 12.0	
11'	Live Load L/240	177	358	387	624	725		355	717	773	1248						
	Total Load	233	473	511	737	817	856	466	947	1022	1474	1451	1634	1713	1711	1709	1703
	End / Int. Bearing	1.5 / 3.3	2.7 / 6.6	2.9 / 7.2	4.1 / 10.3	4.6 / 11.4	4.8 / 12.0	1.5 / 3.3	2.7 / 6.6	2.9 / 7.2	4.1 / 10.3	4.6 / 11.4	4.8 / 12.0	4.8 / 12.0	4.8 / 12.0	4.8 / 12.0	
12'	Live Load L/240	137	279	301	488	569		275	558	603	977						
	Total Load	180	368	397	619	685	784	360	736	795	1237	1371	1569	1567	1565	1559	
	End / Int. Bearing	1.5 / 3.0	2.3 / 5.6	2.4 / 6.1	3.8 / 9.5	4.2 / 10.5	4.8 / 12.0	1.5 / 3.0	2.3 / 5.6	2.4 / 6.1	3.8 / 9.5	4.2 / 10.5	4.8 / 12.0	4.8 / 12.0	4.8 / 12.0	4.8 / 12.0	
13'	Live Load L/240	109	221	239	389	454		218	443	479	778						
	Total Load	142	291	315	513	583	724	283	582	629	1027	1166	1447	1445	1443	1438	
	End / Int. Bearing	1.5 / 3.0	1.9 / 4.9	2.1 / 5.2	3.4 / 8.5	3.9 / 9.7	4.8 / 12.0	1.5 / 3.0	1.9 / 4.9	2.1 / 5.2	3.4 / 8.5	3.9 / 9.7	4.8 / 12.0	4.8 / 12.0	4.8 / 12.0	4.8 / 12.0	
14'	Live Load L/240	87	179	193	315	367		175	357	386	629						
	Total Load	113	234	253	414	484	671	226	468	506	828	735	968	1343	1341	1339	1333
	End / Int. Bearing	1.5 / 3.0	1.7 / 4.2	1.8 / 4.6	3.0 / 7.4	3.5 / 8.7	4.8 / 12.0	1.5 / 3.0	1.7 / 4.2	1.8 / 4.6	3.0 / 7.4	3.5 / 8.7	4.8 / 12.0	4.8 / 12.0	4.8 / 12.0	4.8 / 12.0	
15'	Live Load L/240	71	146	158	258	301		143	292	316	516						
	Total Load	92	190	206	339	396	597	184	381	412	677	603	964	1250	1249	1243	
	End / Int. Bearing	1.5 / 3.0	1.5 / 3.7	1.6 / 4.0	2.6 / 6.5	3.0 / 7.6	4.6 / 11.4	1.5 / 3.0	1.5 / 3.7	1.6 / 4.0	2.6 / 6.5	3.0 / 7.6	4.6 / 11.4	4.8 / 12.0	4.8 / 12.0	4.8 / 12.0	
16'	Live Load L/240	59	121	131	214	250		118	242	262	428						
	Total Load	75	157	170	280	328	524	150	314	340	560	501	803	1048	1171	1169	1164
	End / Int. Bearing	1.5 / 3.0	1.5 / 3.3	1.5 / 3.5	2.3 / 5.8	2.7 / 6.7	4.3 / 10.7	1.5 / 3.0	1.5 / 3.3	1.5 / 3.5	2.3 / 5.8	2.7 / 6.7	4.3 / 10.7	4.8 / 12.0	4.8 / 12.0	4.8 / 12.0	
17'	Live Load L/240	49	101	109	179	210		98	202	219	359						
	Total Load	62	130	141	234	274	443	124	261	283	468	549	887	1102	1100	1094	
	End / Int. Bearing	1.5 / 3.0	1.5 / 3.0	1.5 / 3.1	2.1 / 5.1	2.4 / 6.0	3.9 / 9.7	1.5 / 3.0	1.5 / 3.0	1.5 / 3.1	2.1 / 5.1	2.4 / 6.0	3.9 / 9.7	4.8 / 12.0	4.8 / 12.0	4.8 / 12.0	
18'	Live Load L/240	41	85	92	152	178		83	171	185	304						
	Total Load	52	109	119	197	232	375	104	219	238	394	356	573	840	1040	1038	1032
	End / Int. Bearing	1.5 / 3.0	1.5 / 3.0	1.5 / 3.0	1.8 / 4.6	2.2 / 5.4	3.5 / 8.7	1.5 / 3.0	1.5 / 3.0	1.5 / 3.0	1.8 / 4.6	2.2 / 5.4	3.5 / 8.7	4.8 / 12.0	4.8 / 12.0	4.8 / 12.0	
19'	Live Load L/240		73	79	129	152		71	146	158	259						
	Total Load		93	100	168	197	320	87	186	201	335	394	490	720	944	982	976
	End / Int. Bearing		1.5 / 3.0	1.5 / 3.0	1.7 / 4.2	1.9 / 4.9	3.1 / 7.8	1.5 / 3.0	1.5 / 3.0	1.5 / 3.0	1.7 / 4.2	1.9 / 4.9	3.1 / 7.8	4.6 / 11.5	4.8 / 12.0	4.8 / 12.0	
20'	Live Load L/240		62	67	111	131		61	125	135	223						
	Total Load		79	86	143	169	275	74	158	172	287	337	423	621	870	932	926
	End / Int. Bearing		1.5 / 3.0	1.5 / 3.0	1.5 / 3.8	1.8 / 4.4	2.8 / 7.1	1.5 / 3.0	1.5 / 3.0	1.5 / 3.0	1.5 / 3.8	1.8 / 4.4	2.8 / 7.1	4.2 / 10.5	4.8 / 12.0	4.8 / 12.0	
22'	Live Load L/240		47	51	84	99		45	94	102	168						
	Total Load		58	63	107	126	207	54	117	127	214	252	414	614	846	840	
	End / Int. Bearing		1.5 / 3.0	1.5 / 3.0	1.5 / 3.1	1.5 / 3.7	2.4 / 5.9	1.5 / 3.0	1.5 / 3.0	1.5 / 3.0	1.5 / 3.1	1.5 / 3.7	2.4 / 5.9	3.5 / 8.8	4.8 / 12.0	4.8 / 12.0	
24'	Live Load L/240			39	65	76		73	79	130							
	Total Load			48	81	96	159	88	96	163	153	248	367	516	671	768	
	End / Int. Bearing			1.5 / 3.0	1.5 / 3.0	1.5 / 3.1	2.0 / 5.0	1.5 / 3.0	1.5 / 3.0	1.5 / 3.0	1.5 / 3.1	2.0 / 5.0	3.0 / 7.4	4.2 / 10.4	4.8 / 12.0		
26'	Live Load L/240				51	60		57	62	103							
	Total Load				63	75	124	68	74	126	121	196	290	409	707		
	End / Int. Bearing				1.5 / 3.0	1.5 / 3.0	1.7 / 4.3	1.5 / 3.0	1.5 / 3.0	1.5 / 3.0	1.5 / 3.0	1.7 / 4.3	2.5 / 6.4	3.6 / 9.0	4.8 / 12.0		
28'	Live Load L/240				41	48		46	50	82							
	Total Load				49	59	98	52	57	99	97	158	234	330	655		
	End / Int. Bearing				1.5 / 3.0	1.5 / 3.0	1.5 / 3.7	1.5 / 3.0	1.5 / 3.0	1.5 / 3.0	1.5 / 3.0	1.5 / 3.0	1.5 / 3.7	2.2 / 5.5	3.1 / 7.8	4.8 / 12.0	

KEY TO TABLES

Live Load L/240 = Maximum live load — limits deflection to L/240

Total Load = Maximum total load — limits deflection to L/180

End / Int. Bearing = Required minimum end bearing (inches) for simple or multiple span beams and minimum interior bearing (inches) for multiple span beams based on plate bearing stress of 565 psi.

See "Using Allowable Uniform Floor and Roof Load Tables," page 40.

ALLOWABLE UNIFORM ROOF LOADS (PLF) – 125% (NON-SNOW)

(Can be applied to the beam in addition to its own weight.)

2.0E GP LAM® LVL

SPAN	CONDITION	THREE 1 3/4" GP LAM LVL								FOUR 1 3/4" GP LAM LVL							
		9 1/2"	9 1/2"	11 1/4"	11 1/4"	14"	16"	18"	24"	9 1/2"	9 1/2"	11 1/4"	11 1/4"	14"	16"	18"	24"
6'	Live Load L/240	3858	3991	4730	4729	4726	4723	4720	4712	5144	5321	6307	6305	6301	6298	6294	6283
	Total Load	3958	4101	4870	4869	4866	4863	4860	4852	5244	5421	6407	6405	6401	6398	6394	6383
	End / Int. Bearing	3.9 / 9.8	4.0 / 10.1	4.8 / 12.0	4.8 / 12.0	4.8 / 12.0	4.8 / 12.0	4.8 / 12.0	4.8 / 12.0	3.9 / 9.8	4.0 / 10.1	4.8 / 12.0	4.8 / 12.0	4.8 / 12.0	4.8 / 12.0	4.8 / 12.0	4.8 / 12.0
8'	Live Load L/240	2631								3507							
	Total Load	2714	2801	3437	3543	3540	3537	3534	3525	3619	3735	4583	4723	4719	4716	4712	4701
	End / Int. Bearing	3.7 / 9.2	3.8 / 9.5	4.7 / 11.6	4.8 / 12.0	4.8 / 12.0	4.8 / 12.0	4.8 / 12.0	4.8 / 12.0	3.7 / 9.2	3.8 / 9.5	4.7 / 11.6	4.8 / 12.0	4.8 / 12.0	4.8 / 12.0	4.8 / 12.0	4.8 / 12.0
10'	Live Load L/240	1410	1521	2439						1880	2028	3252					
	Total Load	1849	1945	2624	2798	2828	2825	2822	2813	2466	2593	3499	3730	3770	3766	3763	3751
	End / Int. Bearing	3.1 / 7.8	3.3 / 8.3	4.5 / 11.1	4.7 / 11.9	4.8 / 12.0	4.8 / 12.0	4.8 / 12.0	4.8 / 12.0	3.1 / 7.8	3.3 / 8.3	4.5 / 11.1	4.7 / 11.9	4.8 / 12.0	4.8 / 12.0	4.8 / 12.0	4.8 / 12.0
11'	Live Load L/240	1075	1160	1871						1434	1547	2495					
	Total Load	1420	1533	2212	2450	2569	2566	2563	2555	1894	2045	2949	3267	3425	3421	3418	3406
	End / Int. Bearing	2.7 / 6.6	2.9 / 7.2	4.1 / 10.3	4.6 / 11.4	4.8 / 12.0	4.8 / 12.0	4.8 / 12.0	4.8 / 12.0	2.7 / 6.6	2.9 / 7.2	4.1 / 10.3	4.6 / 11.4	4.8 / 12.0	4.8 / 12.0	4.8 / 12.0	4.8 / 12.0
12'	Live Load L/240	838	904	1465						1117	1206	1953					
	Total Load	1104	1192	1856	2056	2353	2350	2347	2339	1471	1590	2475	2742	3137	3134	3130	3119
	End / Int. Bearing	2.3 / 5.6	2.4 / 6.1	3.8 / 9.5	4.2 / 10.5	4.8 / 12.0	4.8 / 12.0	4.8 / 12.0	4.8 / 12.0	2.3 / 5.6	2.4 / 6.1	3.8 / 9.5	4.2 / 10.5	4.8 / 12.0	4.8 / 12.0	4.8 / 12.0	4.8 / 12.0
13'	Live Load L/240	665	718	1167						886	957	1556					
	Total Load	873	944	1540	1750	2171	2168	2165	2156	1164	1258	2053	2333	2894	2890	2886	2875
	End / Int. Bearing	1.9 / 4.9	2.1 / 5.2	3.4 / 8.5	3.9 / 9.7	4.8 / 12.0	4.8 / 12.0	4.8 / 12.0	4.8 / 12.0	1.9 / 4.9	2.1 / 5.2	3.4 / 8.5	3.9 / 9.7	4.8 / 12.0	4.8 / 12.0	4.8 / 12.0	4.8 / 12.0
14'	Live Load L/240	536	579	944						715	772	1259					
	Total Load	701	759	1243	1453	2014	2011	2008	2000	935	1012	1657	1937	2685	2682	2678	2667
	End / Int. Bearing	1.7 / 4.2	1.8 / 4.6	3.0 / 7.4	3.5 / 8.7	4.8 / 12.0	4.8 / 12.0	4.8 / 12.0	4.8 / 12.0	1.7 / 4.2	1.8 / 4.6	3.0 / 7.4	3.5 / 8.7	4.8 / 12.0	4.8 / 12.0	4.8 / 12.0	4.8 / 12.0
15'	Live Load L/240	438	474	774						584	632	1032					
	Total Load	571	618	1016	1189	1791	1876	1873	1864	761	824	1354	1585	2388	2501	2497	2486
	End / Int. Bearing	1.5 / 3.7	1.6 / 4.0	2.6 / 6.5	3.0 / 7.6	4.6 / 11.4	4.8 / 12.0	4.8 / 12.0	4.8 / 12.0	1.5 / 3.7	1.6 / 4.0	2.6 / 6.5	3.0 / 7.6	4.8 / 12.0	4.8 / 12.0	4.8 / 12.0	4.8 / 12.0
16'	Live Load L/240	363	392	642						484	523	856					
	Total Load	471	510	840	984	1572	1757	1754	1746	627	679	1120	1312	2095	2343	2339	2328
	End / Int. Bearing	1.5 / 3.3	1.5 / 3.5	2.3 / 5.8	2.7 / 6.7	4.3 / 10.7	4.8 / 12.0	4.8 / 12.0	4.8 / 12.0	1.5 / 3.3	1.5 / 3.5	2.3 / 5.8	2.7 / 6.7	4.3 / 10.7	4.8 / 12.0	4.8 / 12.0	4.8 / 12.0
17'	Live Load L/240	304	328	538						405	438	718					
	Total Load	392	424	702	823	1330	1652	1649	1641	522	566	936	1097	1774	2203	2199	2188
	End / Int. Bearing	1.5 / 3.0	1.5 / 3.1	2.1 / 5.1	2.4 / 6.0	3.9 / 9.7	4.8 / 12.0	4.8 / 12.0	4.8 / 12.0	1.5 / 3.0	1.5 / 3.1	2.1 / 5.1	2.4 / 6.0	3.9 / 9.7	4.8 / 12.0	4.8 / 12.0	4.8 / 12.0
18'	Live Load L/240	257	278	456						342	370	608					
	Total Load	329	357	592	695	1126	1559	1556	1548	439	476	789	926	1501	2079	2075	2064
	End / Int. Bearing	1.5 / 3.0	1.5 / 3.0	1.8 / 4.6	2.2 / 5.4	3.5 / 8.7	4.8 / 12.0	4.8 / 12.0	4.8 / 12.0	1.5 / 3.0	1.5 / 3.0	1.8 / 4.6	2.2 / 5.4	3.5 / 8.7	4.8 / 12.0	4.8 / 12.0	4.8 / 12.0
19'	Live Load L/240	219	237	389						292	316	519					
	Total Load	279	302	503	591	961	1417	1473	1465	372	403	670	788	1281	1889	1964	1953
	End / Int. Bearing	1.5 / 3.0	1.5 / 3.0	1.7 / 4.2	1.9 / 4.9	3.1 / 7.8	4.6 / 11.5	4.8 / 12.0	4.8 / 12.0	1.5 / 3.0	1.5 / 3.0	1.7 / 4.2	1.9 / 4.9	3.1 / 7.8	4.6 / 11.5	4.8 / 12.0	4.8 / 12.0
20'	Live Load L/240	188	203	335						251	271	446					
	Total Load	238	258	430	506	825	1220	1398	1390	317	344	574	675	1100	1626	1864	1853
	End / Int. Bearing	1.5 / 3.0	1.5 / 3.0	1.5 / 3.8	1.8 / 4.4	2.8 / 7.1	4.2 / 10.5	4.8 / 12.0	4.8 / 12.0	1.5 / 3.0	1.5 / 3.0	1.5 / 3.8	1.8 / 4.4	2.8 / 7.1	4.2 / 10.5	4.8 / 12.0	4.8 / 12.0
22'	Live Load L/240	142	153	253						189	205	337					
	Total Load	176	191	321	379	621	921	1269	1260	235	255	428	505	827	1228	1692	1680
	End / Int. Bearing	1.5 / 3.0	1.5 / 3.0	1.5 / 3.1	1.5 / 3.7	2.4 / 5.9	3.5 / 8.8	4.8 / 12.0	4.8 / 12.0	1.5 / 3.0	1.5 / 3.0	1.5 / 3.1	1.5 / 3.7	2.4 / 5.9	3.5 / 8.8	4.8 / 12.0	4.8 / 12.0
24'	Live Load L/240	109	118	196						146	158	261					
	Total Load	133	145	245	289	477	711	1006	1152	177	193	327	386	636	948	1342	1537
	End / Int. Bearing	1.5 / 3.0	1.5 / 3.0	1.5 / 3.0	1.5 / 3.1	2.0 / 5.0	3.0 / 7.4	4.2 / 10.4	4.8 / 12.0	1.5 / 3.0	1.5 / 3.0	1.5 / 3.0	1.5 / 3.1	2.0 / 5.0	3.0 / 7.4	4.2 / 10.4	4.8 / 12.0
26'	Live Load L/240	86	93	154						115	124	206					
	Total Load	102	111	190	225	373	558	793	1061	136	148	253	300	497	744	1057	1415
	End / Int. Bearing	1.5 / 3.0	1.5 / 3.0	1.5 / 3.0	1.5 / 3.0	1.7 / 4.3	2.5 / 6.4	3.6 / 9.0	4.8 / 12.0	1.5 / 3.0	1.5 / 3.0	1.5 / 3.0	1.5 / 3.0	1.7 / 4.3	2.5 / 6.4	3.6 / 9.0	4.8 / 12.0
28'	Live Load L/240	69	75	124						92	100	165					
	Total Load	79	86	149	177	296	445	634	983	105	115	199	236	394	593	845	1311
	End / Int. Bearing	1.5 / 3.0	1.5 / 3.0	1.5 / 3.0	1.5 / 3.0	1.5 / 3.7	2.2 / 5.5	3.1 / 7.8	4.8 / 12.0	1.5 / 3.0	1.5 / 3.0	1.5 / 3.0	1.5 / 3.0	1.5 / 3.7	2.2 / 5.5	3.1 / 7.8	4.8 / 12.0

KEY TO TABLES

Live Load L/240 = Maximum live load — limits deflection to L/240

Total Load = Maximum total load — limits deflection to L/180

End / Int. Bearing = Required minimum end bearing (inches) for simple or multiple span beams and minimum interior bearing (inches) for multiple span beams based on plate bearing stress of 565 psi.

See "Using Allowable Uniform Floor and Roof Load Tables," page 40.

FASTENING REQUIREMENTS

GENERAL NOTES:

1. Confirm the adequacy of the beam (depth and thickness) for carrying the designated load.
2. Stress level for nail, bolt and screw values is 100%. Increases of 15% for snow loaded roof conditions or 25% for non-snow roof conditions are permitted.
3. Top and bottom rows of fasteners should be as shown in the fastener clearances detail. For staggered fastening patterns, the maximum end distance applies to all rows.
4. All fasteners must have the length fully embedded, but must not be over-driven, countersunk, or over-tightened.
5. Bolt holes are to be $\frac{1}{32}$ " to $\frac{1}{16}$ " diameter larger than the bolts. Bolts must meet or exceed ASTM A 307 or SAE J429 Grades 1 or 2. Every bolt must extend through the full thickness of the member. Use washers not less than a standard cut washer under the head and nut meeting ANSI B 18.22.1.
6. 7" wide beams should only be side-loaded when loads are applied to both sides, when the lesser side load plf is at least 25% of the opposite side, or when the beam is otherwise restrained to minimize rotation.
7. For beam depths $< 7\frac{1}{4}$ ", the maximum beam thickness must not exceed the beam depth and all fasteners must be staggered up to one-half the required o.c. spacing. For depths $\geq 7\frac{1}{4}$ ", the maximum beam thickness is 7".
8. Fastening recommendations are based on the 2012 National Design Specification for Wood Construction (NDS) or fastener manufacturer's design information.
9. SDS structural screws are produced by Simpson Strong-Tie Company, Inc., WS structural screws are produced by United Steel Products Company, and TrussLok® structural screws are produced by FastenMaster-OMG, Inc. Structural screws must be installed per manufacturer's recommendations.

FASTENER CLEARANCES FOR MULTIPLE-PLY MEMBERS

FASTENER	A		B		C		D
	MIN.	MIN.	MAX.	MIN.	MAX.	MIN.	
10d & 16d Nails	2"	2"	6"	4"	12"	3"	
Bolts & Screws	2"	4"	12"	4"	24"	3"	

Spacings closer than those above may be acceptable, but require special consideration. Contact your technical representative.

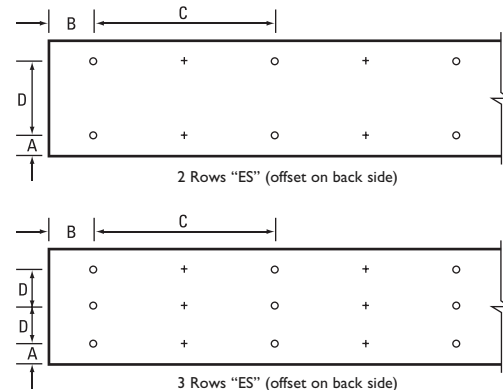

MINIMUM FASTENING REQUIREMENTS FOR TOP- AND SIDE-LOADED MEMBERS

FASTENER TYPE	LVL DEPTH	3 1/2" WIDE	5 1/4" WIDE		7" WIDE		
		2-Ply 1 3/4"	3-Ply 1 3/4"	1 3/4" + 3 1/2"	4-Ply 1 3/4"	2-Ply 1 3/4" + 3 1/2"	2-Ply 3 1/2"
10d (0.128" x 3") Nails	7 1/4" ≤ d < 14"	3 rows @ 12" o.c.	3 rows @ 12" o.c. (ES)	3 rows @ 12" o.c.	-	3 rows @ 12" o.c. (ES)	-
	d ≥ 14"	4 rows @ 12" o.c.	4 rows @ 12" o.c. (ES)	4 rows @ 12" o.c.	-	4 rows @ 12" o.c. (ES)	-
16d (0.162" x 3 1/2") Nails	7 1/4" ≤ d < 14"	2 rows @ 12" o.c.	2 rows @ 12" o.c. (ES)	2 rows @ 12" o.c.	-	2 rows @ 12" o.c. (ES)	-
	d ≥ 14"	3 rows @ 12" o.c.	3 rows @ 12" o.c. (ES)	3 rows @ 12" o.c.	-	3 rows @ 12" o.c. (ES)	-
1/2" Through Bolts	d ≥ 7 1/4"	2 rows @ 24" o.c.	2 rows @ 24" o.c.		2 rows @ 24" o.c.		
SDS 1/4" x 3 1/2", WS35, 3 3/8" TrussLok		2 rows @ 24" o.c.	2 rows @ 24" o.c. (ES)	2 rows @ 24" o.c.	-	2 rows @ 24" o.c. (ES)	-
SDS 1/4" x 6", WS6		-	-		2 rows @ 24" o.c. (ES)		
5" TrussLok		-	2 rows @ 24" o.c.		-		
6 3/4" TrussLok		-	-		2 rows @ 24" o.c.		

NOTES:

1. All fasteners must meet the minimum requirements in the table above. Side-loaded multiple-ply members must meet the minimum fastening and side-loading capacity requirements given on page 48.
2. Minimum fastening requirements for depths less than 7 1/4" require special consideration. Please contact your technical representative.
3. Three general rules for staggering or offsetting for a certain fastener schedule:
 - (1) if staggering or offsetting is not referenced, then none is required;
 - (2) if staggering is referenced, then fasteners installed in adjacent rows on the front side are to be staggered up to one-half the o.c. spacing, but maintaining the fastener clearances above; and
 - (3) if "ES" is referenced, then the fastener schedule must be repeated on each side, with the fasteners on the back side offset up to one-half the o.c. spacing of the front side (whether or not it is staggered).

TOP-LOADED

For required multiple-ply member fastening, only conditions where the loading is applied evenly across the top of all plies shall be considered "top-loaded." All other conditions must be fastened using the side-loaded

recommendations on page 48. All top-loaded multiple-ply LVL members must meet the **minimum fastener requirements** and required fastener spacing shown above.

FASTENING REQUIREMENTS (CONTINUED)

2.0E GP LAM® LVL SIDE-LOADED

For required multiple-ply member fastening, conditions where the loading is not applied evenly across the top of all plies shall be considered side-loaded. All side-loaded multiple-ply members must meet the **minimum fastener requirements** on page 47 and the loading capacity requirements below.

MAXIMUM UNIFORM LOAD APPLIED TO EITHER OR BOTH OUTSIDE PLYS (PLF)

Refer to General Notes page 47.

- Numbers in the table indicate load in pounds per lineal foot which may be applied to either side, except as shown in note 6 on page 47, based solely on the connection.
- Framing members must be attached with approved metal hangers. Refer to pages 27, 51 and 52 for hanger recommendations.
- This table applies to uniform loading only. Concentrated (point) side loads may require additional consideration.

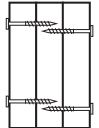
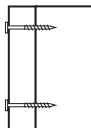
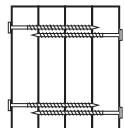
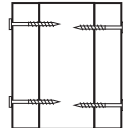
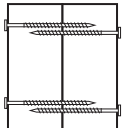
FASTENER SCHEDULE			3½" WIDE	5¼" WIDE		7" WIDE		
FASTENER TYPE	NUMBER OF FASTENER ROWS	FASTENER ON-CENTER SPACING (IN.)						
			2-Ply 1¾"	3-Ply 1¾"	1¾" + 3½"	4-Ply 1¾"	2-Ply 1¾" + 3½"	2-Ply 3½"
10d (0.128" x 3") Nails	3	12	545	405 (ES)	405	—	360 (ES)	—
	4	12	725	545 (ES)	545	—	485 (ES)	—
16d (0.162" x 3½") Nails	2	12	565	425 (ES)	425	—	375 (ES)	—
	3	12	845	635 (ES)	635	—	563 (ES)	—
½" Through Bolts	2	24	505	380	525	340	465	860
		19.2	635	475	655	425	585	1075
		16	760	570	790	505	700	1290
SDS ¼" x 3½"	2	24	680	510 (ES)	510	—	455 (ES)	—
		19.2	850	640 (ES)	640	—	565 (ES)	—
		16	1020	765 (ES)	765	—	680 (ES)	—
SDS ¼" x 6"	2	24	—	—	—	555 (ES)	555 (ES)	680 (ES)
		19.2	—	—	—	695 (ES)	695 (ES)	850 (ES)
		16	—	—	—	835 (ES)	835 (ES)	1020 (ES)
USP WS35	2	24	500	375 (ES)	375	—	335 (ES)	—
		19.2	625	470 (ES)	470	—	415 (ES)	—
		16	750	565 (ES)	565	—	500 (ES)	—
USP WS6	2	24	—	—	—	335 (ES)	335 (ES)	500 (ES)
		19.2	—	—	—	415 (ES)	415 (ES)	625 (ES)
		16	—	—	—	500 (ES)	500 (ES)	750 (ES)
3¾" TrussLok®	2	24	535	400 (ES)	400	—	355 (ES)	—
		19.2	670	500 (ES)	500	—	445 (ES)	—
		16	800	600 (ES)	600	—	535 (ES)	—
5" TrussLok	2	24	—	435	435	—	385 (ES)	580 (ES)
		19.2	—	545	545	—	485 (ES)	725 (ES)
		16	—	655	655	—	580 (ES)	870 (ES)
6¾" TrussLok	2	24	—	—	—	385	385	580
		19.2	—	—	—	485	485	725
		16	—	—	—	580	580	870

NOTES:

1. "ES" indicates fasteners must be installed from **each side** of the beam with the given fastening schedule. Stagger fasteners on opposite side of beam by up to one-half the required fastener on-center spacing.
2. For nails, tabulated values may be multiplied by 2.0 for 6" o.c. spacing and by 3.0 for 4" o.c. spacing. For bolts, tabulated values for 24" o.c. may be multiplied by 2.0 for 12" o.c. spacing. For structural screws, tabulated values for 24" o.c. may be multiplied by 2.0 for 12" o.c. spacing, by 4.0 for 6" o.c. spacing and by 6.0 for 4" o.c. spacing.
3. For 3 rows of fasteners, multiply tabulated values for 2 rows by 1.5. Center and stagger middle row by one-half the required o.c. spacing for depths less than 11¼".
4. Do not use fastener schedule if fastener clearances, required staggering and offsetting, or required fastening cannot be met. Consult technical representative for other options.

TAPERED CUT ALLOWABLE END REACTION – TRUSS ROOF

3/2" THICK GP LAM® LVL BEAMS ALLOWABLE END REACTION (LBS)

LVL DEPTH	TRUSS CHORD SIZE	BEAM BEARING LENGTH	TRUSS SLOPE									
			4/12		6/12		8/12		10/12		12/12	
			D _{OUTSIDE} (INCHES)	REACTION (LBS)	D _{OUTSIDE} (INCHES)	REACTION (LBS)	D _{OUTSIDE} (INCHES)	REACTION (LBS)	D _{OUTSIDE} (INCHES)	REACTION (LBS)	D _{OUTSIDE} (INCHES)	REACTION (LBS)
7 1/4"	2x4	3 1/2"	3 15/16	3395	4 3/16	4419	4 7/16	4790	4 13/16	Max.	5 3/16	Max.
		5 1/4"	3 15/16	3967	4 3/16	4779	4 7/16	Max.	4 13/16	Max.	5 3/16	Max.
2x6	2x4	3 1/2"	6 1/16	4821	6 3/8	Max.	6 7/8	Max.	7 1/4	Max.	7 1/4	Max.
		5 1/4"	6 1/16	Max.	6 3/8	Max.	6 7/8	Max.	7 1/4	Max.	7 1/4	Max.
9 1/4" or 9 1/2"	2x4	3 1/2"	3 15/16	3395	4 3/16	3932	4 7/16	5238	4 13/16	5910	5 3/16	6128
		5 1/4"	3 15/16	3783	4 3/16	4877	4 7/16	5941	4 13/16	6151	5 3/16	Max.
2x6	2x4	3 1/2"	6 1/16	4873	6 3/8	5953	6 7/8	6151	7 1/16	Max.	8	Max.
		5 1/4"	6 1/16	5576	6 3/8	6144	6 7/8	Max.	7 1/16	Max.	8	Max.
11 1/4" or 11 7/8"	2x4	3 1/2"	3 15/16	—	4 3/16	3932	4 7/16	4515	4 13/16	6115	5 3/16	6921
		5 1/4"	3 15/16	—	4 3/16	4514	4 7/16	5972	4 13/16	7109	5 3/16	7440
2x6	2x4	3 1/2"	6 1/16	4797	6 3/8	5631	6 7/8	6921	7 7/16	6921	8	6921
		5 1/4"	6 1/16	5185	6 3/8	6699	6 7/8	7405	7 7/16	7481	8	Max.
14"	2x4	3 1/2"	3 15/16	—	4 3/16	—	4 7/16	—	4 13/16	5238	5 3/16	6921
		5 1/4"	3 15/16	—	4 3/16	—	4 7/16	—	4 13/16	7291	5 3/16	8508
2x6	2x4	3 1/2"	6 1/16	4797	6 3/8	5419	6 7/8	6803	7 7/16	6921	8	6921
		5 1/4"	6 1/16	5185	6 3/8	6001	6 7/8	8034	7 7/16	8978	8	9284
16"	2x6	3 1/2"	6 1/16	4797	6 3/8	5419	6 7/8	6114	7 7/16	6921	8	6921
		5 1/4"	6 1/16	5185	6 3/8	6001	6 7/8	7577	7 7/16	9437	8	10269
18"	2x6	3 1/2"	6 1/16	4797	6 3/8	5419	6 7/8	6114	7 7/16	6921	8	6921
		5 1/4"	6 1/16	5185	6 3/8	6001	6 7/8	6890	7 7/16	9354	8	10382
24"	2x6	3 1/2"	6 1/16	—	6 3/8	—	6 7/8	—	7 7/16	—	8	6921
		5 1/4"	6 1/16	—	6 3/8	—	6 7/8	—	7 7/16	—	8	10203

NOTES:

- Prior to using this table, beam size must be checked by tables or FASTBeam® software.
- Table can also be used for 1 3/4", 5/4" and 7" thick GP Lam LVL beams
For 1 3/4" thick beam: 0.5 x allowable reaction (lbs)
For 5/4" thick beam: 1.5 x allowable reaction (lbs)
For 7" thick beam: 2.0 x allowable reaction (lbs)
- Provide lateral support at bearing points, and continuous lateral support along top (or compression edge) of beam.
- Listed values are for 2.0E GP Lam LVL beam products.
- Special consideration is required for uplift reactions.
- Concentrated loads, holes, and other notches are not allowed in the tapered cut region.
- Southern Pine bearing plate assumed (565 psi).
- Values are for floor use, 100% duration of load increase.
- If "Max." is shown in Reaction column, full capacity is available.
- If no allowable reaction is shown, beam will not work with current input; try using a shallower beam with additional plies.
- Field verify slope and all dimensions.
- 1/4" butt cut height assumed for truss bottom chord.

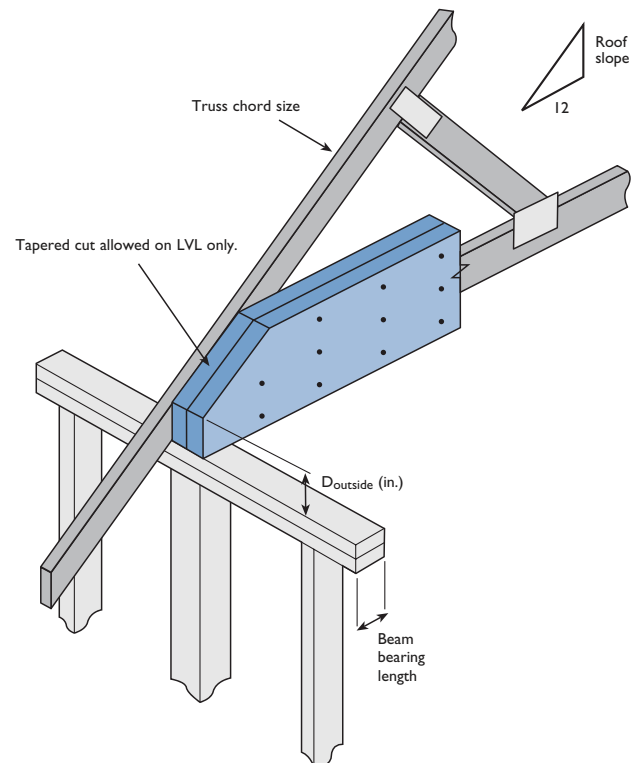

TAPERED CUT ALLOWABLE END REACTION - CONVENTIONAL (STICK) ROOF

3/2" THICK GP LAM® LVL BEAMS ALLOWABLE END REACTION (LBS)

LVL DEPTH	RAFTER SIZE	BEAM BEARING LENGTH	RAFTER SLOPE									
			4/12		6/12		8/12		10/12		12/12	
			D _{OUTSIDE} (INCHES)	REACTION (LBS)	D _{OUTSIDE} (INCHES)	REACTION (LBS)	D _{OUTSIDE} (INCHES)	REACTION (LBS)	D _{OUTSIDE} (INCHES)	REACTION (LBS)	D _{OUTSIDE} (INCHES)	REACTION (LBS)
7 1/4"	2x6	3 1/2"	4 5/8	4095	4 3/8	4559	4 1/4	4759	4 1/4	4820	4 1/4	Max.
		5 1/4"	4 1/16	4095	3 1/2	4559	3 3/8	4759	2 13/16	4820	2 1/2	Max.
7 1/4"	2x8	3 1/2"	6 1/2	Max.	6 3/8	Max.	6 3/8	Max.	6 1/2	Max.	6 3/4	Max.
		5 1/4"	5 7/8	Max.	5 1/2	Max.	5 3/16	Max.	5 1/16	Max.	5	Max.
9 1/4" or 9 1/2"	2x6	3 1/2"	4 5/8	3855	4 3/8	4089	4 1/4	5057	4 1/4	5664	4 1/4	5966
		5 1/4"	4 1/16	3855	3 1/2	4089	3 3/8	—	2 13/16	—	2 1/2	—
9 1/4" or 9 1/2"	2x8	3 1/2"	6 1/2	5416	6 3/8	5936	6 3/8	6118	6 1/2	6151	6 3/4	Max.
		5 1/4"	5 7/8	5416	5 1/2	5936	5 3/16	6118	5 1/16	6151	5	Max.
9 1/4" or 9 1/2"	2x10	3 1/2"	8 7/16	Max.	8 7/16	Max.	8 13/16	Max.	9 1/8	Max.	9 1/4	Max.
		5 1/4"	8	Max.	7 11/16	Max.	7 9/8	Max.	7 11/16	Max.	7 13/16	Max.
11 1/4" or 11 7/8"	2x6	3 1/2"	4 5/8	3855	4 3/8	4089	4 1/4	4396	4 1/4	5418	4 1/4	6451
		5 1/4"	4 1/16	3855	3 1/2	—	3 3/8	—	2 13/16	—	2 1/2	—
11 1/4" or 11 7/8"	2x8	3 1/2"	6 1/2	5082	6 3/8	5566	6 3/8	6745	6 1/2	6921	6 3/4	6921
		5 1/4"	5 7/8	5082	5 1/2	5566	5 3/16	6745	5 1/16	7203	5	7417
11 1/4" or 11 7/8"	2x10	3 1/2"	8 7/16	6921	8 7/16	6921	8 13/16	6921	9 1/8	Max.	9 9/16	Max.
		5 1/4"	8	6973	7 11/16	7375	7 9/8	7480	7 11/16	Max.	7 13/16	Max.
11 1/4" or 11 7/8"	2x12	3 1/2"	10 11/16	6921	10 13/16	Max.	11 3/16	Max.	11 1/4	Max.	11 1/4	Max.
		5 1/4"	10 5/8	7481	9 15/16	Max.	10	Max.	10 1/4	Max.	10 11/16	Max.
14"	2x8	3 1/2"	6 1/2	5082	6 3/8	5390	6 3/8	6111	6 1/2	6921	6 3/4	6921
		5 1/4"	5 7/8	5082	5 1/2	5390	5 3/16	6111	5 1/16	7550	5	8399
14"	2x10	3 1/2"	8 7/16	6484	8 7/16	6921	8 13/16	6921	9 1/8	6921	9 9/16	6921
		5 1/4"	8	6484	7 11/16	7589	7 9/8	8564	7 11/16	9056	7 13/16	9267
14"	2x12	3 1/2"	10 11/16	6921	10 13/16	6921	11 3/16	6921	11 3/4	Max.	12 1/16	Max.
		5 1/4"	10 5/8	8539	9 15/16	9096	10	9293	10 1/4	Max.	10 11/16	Max.
16"	2x8	3 1/2"	6 1/2	5082	6 3/8	5390	6 3/8	5794	6 1/2	6921	6 3/4	6921
		5 1/4"	5 7/8	5082	5 1/2	5390	5 3/16	—	5 1/16	—	5	—
16"	2x10	3 1/2"	8 7/16	6484	8 7/16	6877	8 13/16	6921	9 1/8	6921	9 9/16	6921
		5 1/4"	8	6484	7 11/16	6877	7 9/8	8501	7 11/16	9601	7 13/16	10207
16"	2x12	3 1/2"	10 11/16	6921	10 13/16	6921	11 3/16	6921	11 3/4	6921	12 1/16	6921
		5 1/4"	10 5/8	7886	9 15/16	9402	10	10187	10 1/4	10382	10 11/16	10382
18"	2x8	3 1/2"	6 1/2	5082	6 3/8	5390	6 3/8	5794	6 1/2	6276	6 3/4	6921
		5 1/4"	5 7/8	—	5 1/2	—	5 3/16	—	5 1/16	—	5	—
18"	2x10	3 1/2"	8 7/16	6484	8 7/16	6877	8 13/16	6921	9 1/8	6921	9 9/16	6921
		5 1/4"	8	6484	7 11/16	6877	7 9/8	7719	7 11/16	9616	7 13/16	10382
18"	2x12	3 1/2"	10 11/16	6921	10 13/16	6921	11 3/16	6921	11 3/4	6921	12 1/16	6921
		5 1/4"	10 5/8	7886	9 15/16	8861	10	10382	10 1/4	10382	10 11/16	10382
24"	2x10	3 1/2"	8 7/16	6484	8 7/16	6877	8 13/16	6921	9 1/8	6921	9 9/16	6921
		5 1/4"	8	6484	7 11/16	—	7 9/8	—	7 11/16	—	7 13/16	—
24"	2x12	3 1/2"	10 11/16	6921	10 13/16	6921	11 3/16	6921	11 3/4	6921	12 1/16	6921
		5 1/4"	10 5/8	7886	9 15/16	8364	10	8991	10 1/4	10382	10 11/16	10382

NOTES:

- Prior to using this table, beam size must be checked by tables or FASTBeam® software.
- Table can also be used for 1 3/4", 5/4" and 7" thick GP Lam LVL beams
For 1 3/4" thick beam: 0.5 x allowable reaction (lbs)
For 5/4" thick beam: 1.5 x allowable reaction (lbs)
For 7" thick beam: 2.0 x allowable reaction (lbs)
- Provide lateral support at bearing points, and continuous lateral support along top (or compression edge) of beam.
- Listed values are for 2.0E GP Lam LVL beam products.
- Special consideration is required for uplift reactions.
- Concentrated loads, holes, and other notches are not allowed in the tapered cut region.
- Southern Pine bearing plate assumed (565 psi).
- Values are for floor use, 100% duration of load increase.
- If "Max." is shown in Reaction column, full capacity is available.
- If no allowable reaction is shown, beam will not work with current input; try using a shallower beam with additional plies.
- Field verify slope and all dimensions.

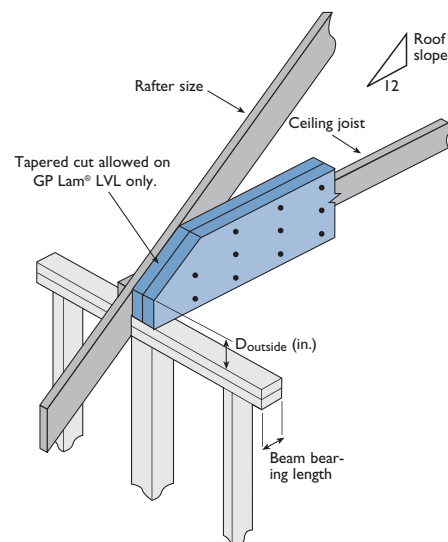

USP STRUCTURAL CONNECTORS™ FOR GP LAM® LVL



GP LAM LVL MEMBER SUPPORTED		TOP MOUNT	CAPACITY 100% (LBS)	FACE MOUNT	CAPACITY 100% (LBS)
THICKNESS	BEAM DEPTH				
1 3/4"	7 1/4"	PHXU17725	4425	HD1770	1975
	9 1/4"	PHXU17925	4420	HD17925	2540
	9 1/2"	PHXU1795	4420	HD17925	2540
	11 1/4"	PHXU17112	4420	HD17112	2870
	11 7/8"	PHXU17118	4420	HD17112	2870
	14"	PHXU1714	4420	HD1714	3100
3 1/2"	7 1/4"	—	—	—	—
	9 1/4"	PHXU35925	6650	THDH410	8260
	9 1/2"	PHXU3595	6650	THDH410	8260
	11 1/4"	PHXU35112	6650	THDH412	9845
	11 7/8"	PHXU35118	6650	THDH412	9845
	14"	HLBH3514	10620	THDH414	9845
	16"	HLBH3516	10620	THDH414	9845
	18"	HLBH3518	10620	THDH414	9845
5 1/4"	7 1/4"	—	—	—	—
	9 1/4"	HLBH55925	10620	THDH610	8725
	9 1/2"	HLBH5595	10620	THDH610	8725
	11 1/4"	HLBH55112	10620	THDH612	9935
	11 7/8"	HLBH55118	10620	THDH612	9935
	14"	HLBH5514	10620	THDH614	11645
	16"	HLBH5516	10620	THDH614	11645
	18"	HLBH5518	10620	THDH614	11645
7"	9 1/4"	HLBH71925	10620	THDH7210	8260
	9 1/2"	HLBH7195	10620	THDH7210	8260
	11 1/4"	HLBH71112	10620	THDH7212	9845
	11 7/8"	HLBH71118	10620	THDH7212	9845
	14"	HLBH7114	10620	THDH7214	9845
	16"	HLBH7116	10620	THDH7214	9845
	18"	HLBH7118	10620	THDH7214	9845
24"	HLBH7124	10620	—	—	

USP BEAM-TO-COLUMN CONNECTORS FOR GP LAM LVL

COLUMN CAP	CAPACITY* 100% (LBS)	W1	COLUMN **	W2	L	H
KCCQ44	24065	3 3/8"	4 x __Wood	3 3/8"	11"	6 1/2"
KCCQ46	24065	3 3/8"	6 x __Wood	5 1/2"	11"	6 1/2"
KCCQ48	24065	3 3/8"	8 x __Wood	7 1/2"	11"	6 1/2"
KCCQ64	37815	5 1/2"	4 x __Wood	3 3/8"	11"	6 1/2"
KCCQ66	37815	5 1/2"	6 x __Wood	5 1/2"	11"	6 1/2"
KCCQ68	37815	5 1/2"	8 x __Wood	7 1/2"	11"	6 1/2"
KCCQ84	51565	7 1/2"	4 x __Wood	3 3/8"	11"	6 1/2"
KCCQ86	51565	7 1/2"	6 x __Wood	5 1/2"	11"	6 1/2"
KCCQ88	51565	7 1/2"	8 x __Wood	7 1/2"	11"	6 1/2"
KLCC35-4	21000	3 3/8"	4" dia. steel	—	11 1/2"	4"
KLCC525-4	21000	5 3/8"	4" dia. steel	—	11 1/2"	4"
KLCC7-4	21000	7 7/8"	4" dia. steel	—	11 1/2"	4"

* Capacity is maximum capacity of the USP column cap.
 ** Adequacy of column to be verified by others.

NOTES:

- Capacity is for the stated duration of load—100% floor loading. Hanger capacity depends on the hanger selected, quantity and size of fasteners used, and the size and type of support to which it is fastened. **Hanger capacities shown are based on attachment to LVL header material using the hanger manufacturer's recommended fastening. Minimum header thickness is 3 1/2".** Some hanger/header/fastener combinations may not meet maximum beam capacities and a qualified designer should be consulted. Before selecting hangers, please refer to the appropriate reference/design guide from the hanger manufacturer for expanded design information. Many other designs are available for specialized applications.
- Model numbers shown are for United Steel Products Company, Inc. and Simpson Strong-Tie® Company, Inc. Contact your local building material supplier for connector availability.
- Special consideration is required with top mount hangers on nailers. Refer to the hanger manufacturer's catalog for reduced capacity.

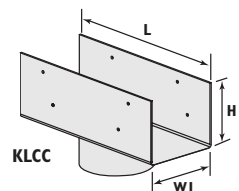
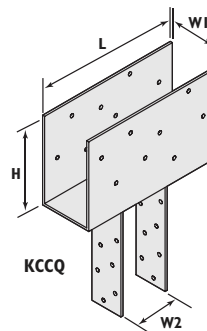

**SIMPSON STRONG-TIE®
CONNECTORS FOR
GP LAM® LVL**

Refer to notes on page 51.

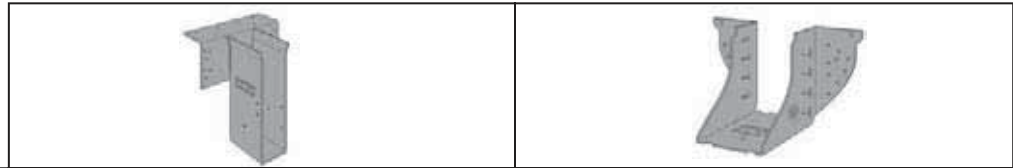

GP LAM LVL MEMBER SUPPORTED		TOP MOUNT	CAPACITY 100% (LBS)	FACE MOUNT	CAPACITY 100% (LBS)
THICKNESS	BEAM DEPTH				
1 3/4"	7/4"	LBV1.81/7.25	2910	HU7 (MAX)	2380
	9/4"	LBV1.81/9.25	2910	HUS1.81/10	5135
	9/2"	MIT9.5	2550	HUS1.81/10	5135
	11/4"	B1.81/11.25	4135	HUS1.81/10	5135
	11/8"	BA1.81/11.88	4015	HUS1.81/10	5135
	14"	B1.81/14	4135	HUS1.81/10	5135
3 1/2"	7/4"	B3.56X	4135	HHUS48	4210
	9/4"	HB3.56/9.25	5815	HHUS410	5635
	9/2"	HB3.56/9.5	5815	HHUS410	5635
	11/4"	HB3.56/11.25	5815	HHUS410	5635
	11/8"	HB3.56/11.88	5815	HHUS410	5635
	14"	GLTV3.514	7500	HGUS414	10100
	16"	GLTV3.516	7500	HGUS414	10100
	18"	HGLTV3.518	10500	HGUS414	10100
5 1/4"	7/4"	HB5.50X	5815	HGUS5.50/8	7460
	9/4"	GLTV5.50/9.25	7500	HGUS5.50/10	9100
	9/2"	GLTV5.59	7500	HGUS5.50/10	9100
	11/4"	GLTV5.50/11.25	7500	HGUS5.50/12	9600
	11/8"	HGLTV5.511	10500	HGUS5.50/12	9600
	14"	HGLTV5.514	10500	HGUS5.50/14	10100
	16"	HGLTV5.516	10500	HGUS5.50/14	10100
	18"	EGQ5.50	19800	HGU5.50-SDS	14145
7"	9/4"	GLTV49.25-2	7500	HGUS7.25/10	9100
	9/2"	GLTV49.5-2	7500	HGUS7.25/10	9100
	11/4"	HGLTV411.25-2	10500	HGUS7.25/12	9600
	11/8"	HGLTV411.88-2	10500	HGUS7.25/12	9600
	14"	EGQ7.25	19800	HGU7.25/14	10100
	16"	EGQ7.25	19800	HGU7.25-SDS	14145
	18"	EGQ7.25	19800	HHGU7.25-SDS	17845
	24"	EGQ7.25	19800	HHGU7.25-SDS	17845

SIMPSON BEAM-TO-COLUMN CONNECTORS FOR GP LAM LVL

COLUMN CAP	CAPACITY* 100% (LBS)	W1	COLUMN**	W2	L	H	COLUMN CAP	CAPACITY* 100% (LBS)	W1	COLUMN**	W2	L	H
CC44	15310	3 5/8"	4 x __Wood	3 5/8"	7"	4"	CCQ44SDS2.5	19020	3 5/8"	4 x __Wood	3 5/8"	11"	7"
CC46	24060	3 5/8"	6 x __Wood	5 1/2"	11"	6 1/2"	CCQ46SDS2.5	24065	3 5/8"	6 x __Wood	5 1/2"	11"	7"
CC48	24060	3 5/8"	8 x __Wood	7 1/2"	11"	6 1/2"	CCQ48SDS2.5	24065	3 5/8"	8 x __Wood	7 1/2"	11"	7"
CC64	28586	5 1/2"	4 x __Wood	3 5/8"	11"	6 1/2"	CCQ64SDS2.5	28585	5 1/2"	4 x __Wood	3 5/8"	11"	7"
CC66	30250	5 1/2"	6 x __Wood	5 1/2"	11"	6 1/2"	CCQ66SDS2.5	30250	5 1/2"	6 x __Wood	5 1/2"	11"	7"
CC68	37810	5 1/2"	8 x __Wood	7 1/2"	11"	6 1/2"	CCQ68SDS2.5	37815	5 1/2"	8 x __Wood	7 1/2"	11"	7"
CC7 1/2-6	38500	7 1/8"	6 x __Wood	5 1/2"	13"	8"	CCQ7 1/2-6SDS2.5	38500	7 1/8"	6 x __Wood	5 1/2"	11"	7"
CC7 1/2-8	52500	7 1/8"	8 x __Wood	7 1/2"	13"	8"	CCQ7 1/2-8SDS2.5	52500	7 1/8"	8 x __Wood	7 1/2"	11"	7"
LCC3.5-4	20670	3 5/8"	4" dia. steel	-	11 1/2"	4"							
LCC5.25-4	20670	5 3/8"	4" dia. steel	-	11 1/2"	4"							
LCC7-4	20670	7 1/8"	4" dia. steel	-	11 1/2"	4"							

* Capacity is maximum capacity of the Simpson column cap.

** Adequacy of column to be verified by others.

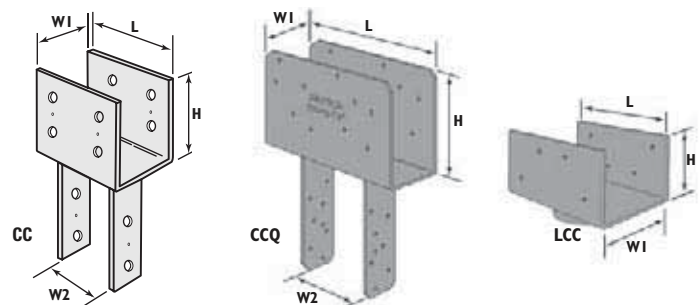

GP LAM[®] LVL BEAM AND HEADER DESIGN PROPERTIES

1 3/4" 2.0E GP LAM LVL ALLOWABLE EDGEWISE DESIGN PROPERTIES^A

DEPTH ^B	EI (10 ⁶ INCH ⁴ LBS)	MAXIMUM RESISTIVE MOMENT (FT-LBS)			MAXIMUM VERTICAL SHEAR (LBS)			WEIGHT (LBS/FT)
		100%	115%	125%	100%	115%	125%	
7 1/4"	111	3918	4506	4898	2411	2772	3013	3.4
9 1/4"	231	6208	7139	7760	3076	3537	3845	4.4
9 1/2"	250	6529	7508	8161	3159	3633	3948	4.5
11 1/4"	415	8985	10333	11231	3741	4302	4676	5.3
11 7/8"	488	9951	11444	12439	3948	4541	4936	5.6
14"	800	13581	15618	16976	4655	5353	5819	6.6
16" ^B	1195	17477	20098	21846	5320	6118	6650	7.6
18" ^B	1701	21831	25106	27289	5985	6883	7481	8.5
24" ^B	4032	37591	43229	46988	7980	9177	9975	11.4

A. Table assumes beam has lateral support at bearing points and continuous lateral support along the compression edge of the beam.

B. 1 3/4" beams deeper than 14" must only be used in multiple-ply members.

2.0E GP LAM ALLOWABLE EDGEWISE DESIGN STRESSES¹

Modulus of Elasticity	E	=	2.0 × 10 ⁶ psi ²
Shear Modulus of Elasticity	G	=	125,000 psi
Flexural Stress	F _b	=	2,900 psi ³
Horizontal Shear	F _v	=	285 psi
Compression Perpendicular to Grain	F _{c⊥}	=	845 psi ²
Compression Parallel to Grain	F _c	=	2,600 psi
Equivalent Specific Gravity	SG	=	0.50

1. Allowable design stresses apply to depths as small as 3 1/2" ripped from any depth of beam.
2. No increase is allowed to E, G or F_{c⊥} for duration of load.
3. For depths (d) other than 12" multiply F_b by (12/d)^{1/9}.
4. When calculating deflection, both bending and shear deformations must be included.
The deflection equation for a simply-supported beam under uniform load is:

$$\Delta = \frac{270 w L^4}{E b h^3} + \frac{28.8 w L^2}{E b h}$$

Where: Δ = estimated deflection, inches w = uniform load, plf
L = span, feet E = tabulated modulus of elasticity, psi
b = beam width, inches h = beam depth, inches

For other spans or loading conditions, see engineering references or use design software.

GP LAM[®] LVL ARCHITECTURAL SPECIFICATIONS

Part 1 — General

1.0 — Description

- A. Work in this section includes, but is not limited to:
Laminated Veneer Lumber (LVL) beams and headers.
- B. Related work specified elsewhere:
Rough carpentry.

1.1 — Submittals:

- A. Product data:
Submit manufacturer's descriptive literature indicating material composition, thicknesses, dimensions, loading and fabrication details.
- B. Shop drawings:
Submit manufacturer's literature indicating installation details. Include locations and details of bearing, blocking, bridging and cutting for work by others.

1.2 — Quality Assurance:

- A. Certification:
All GP Lam[®] LVL has been qualified to ASTM D 5456 by APA-The Engineered Wood Association.

1.3 — Delivery, Storage and Handling:

- A. Delivery:
Deliver materials to the job site in manufacturer's original packaging, containers and bundles with manufacturer's identification intact and legible.
- B. Storage and handling:
Store and handle materials to protect against contact with damp and wet surfaces, exposure to weather, breakage and damage. Provide air circulation under covering and around stacks of materials.

1.4 — Limitations:

- A. Cutting:
Except for cutting to length, GP Lam LVL beams and headers shall not be cut, drilled or notched, except as noted in manufacturer's literature.
- B. Moisture conditions:
GP Lam LVL is for use in covered, dry-use conditions only (moisture content less than 16%).

Part 2 — Products

2.0 — Prefabricated wood beams and headers:

- A. Acceptable products: 2.0E
 1. Georgia-Pacific, GP Lam LVL floor and roof beams.
 2. Georgia-Pacific, GP Lam LVL window and door headers.
- B. Characteristics:
 1. Construction:
1¾" and 3½" thick pressure bonded, lap-jointed wood veneers, with grain of veneers running parallel in the long direction.
 2. Standard beam sizes:
2.0E—1¾" x 7¼", 9¼", 9½", 11¼", 11¾", 14", 16", 18", 24"
As required for loading, deflection and span.
 3. Beam length:
As required for span and bearing.

2.1 — Accessories:

- A. Fasteners:
16d common nails, approved structural screws or ½" bolts.
- B. Hangers:
 1. Contact GP or an engineer for acceptable connectors.

Part 3 — Execution

3.0 — General:

- A. Provide GP Lam LVL beams and headers where indicated on drawings using hangers and accessories specified.
- B. Install GP Lam LVL beams and headers in accordance with manufacturer's recommendations.

3.1 — Accessories:

Install accessories where indicated and in accordance with beam and header manufacturer's instructions.

SALES, UPDATES AND CURRENT INFORMATION

The sale of our engineered lumber products is subject to our terms of sale which are available at www.gp.com/tc or upon request. The information in this document may change without notice. Visit our website at www.buildgp.com for updates and current information or call 877-437-9759 to request a current copy.

GENERAL

The user is responsible for proper installation of our engineered lumber products. Our engineered lumber products must be installed in strict conformity with our instructions and all applicable building code requirements and other regulations. In addition, if not specifically covered by our installation instructions or construction detail

illustrations, the products must be installed in accordance with generally accepted design and construction practices. When installing engineered lumber products, the user must also consider the effects of local climate and geography. We do not warrant and are not responsible for the design and construction of any finished structure or system into which our engineered lumber products may be incorporated or other building components that may be used with our products.

LIFETIME LIMITED WARRANTY

Georgia-Pacific engineered lumber products are covered by a lifetime limited warranty. For complete warranty details, terms and conditions, please visit www.buildgp.com or call 877-437-9759.

HEALTH AND SAFETY CAUTION

Georgia-Pacific engineered lumber products are manufactured with one or more of the following adhesives: phenol-formaldehyde, phenol-resorcinol-formaldehyde, melamine, polyurethane emulsion polymer, isocyanate and/or polyurethane. Georgia-Pacific engineered lumber products contain no added urea formaldehyde resins. A Material Safety Data Sheet (MSDS) containing potential physical and health hazard information is available from your employer or by contacting the Products Safety and Health Information Department at Georgia-Pacific LLC, P.O. Box 105605, Atlanta, GA 30348-5605, 404-652-5119 or visit www.buildgp.com.

ENGINEERED FOR PERFORMANCE

WHAT YOU DON'T SEE MATTERS™



Georgia-Pacific Wood Products LLC
133 Peachtree Street
Atlanta, Georgia 30303
877-437-9759

When it comes to floor joists, rim board, beams and headers, builders and contractors choose Georgia-Pacific engineered lumber for many reasons. Today's residential building trends call for large, open spaces and high ceilings, creating a demand for products that provide higher strength and greater stability over longer spans.

Georgia-Pacific engineered lumber products are covered by a lifetime limited warranty. For complete warranty details, terms and conditions, please visit www.buildgp.com or call 877-437-9759.



This NGBS Green Certified mark is your assurance that a product is Home Innovation NGBS Green Certified for Resource Efficiency and Indoor Environmental Quality. Please visit Homeinnovation.com/Green for more information.



Engineered lumber from Georgia-Pacific is made from wood that is sourced through a system that is third-party certified to the Sustainable Forestry Initiative® (SFI®) procurement standard.

Unless otherwise noted, all trademarks are owned by or licensed to Georgia-Pacific Wood Products LLC. APA Rated and Sturd-I-Floor are registered trademarks of APA-The Engineered Wood Association. TrussLok and FastenMaster are registered trademarks of Olympic Manufacturing Group, Inc. Simpson Strong-Tie is a registered trademark of Simpson Strong-Tie Company, Inc. USP Structural Connectors is a trademark of MiTek USA, Inc. Tough-Glass and Summit are trademarks owned by Atlas Roofing Corp. Monier is a trademark owned by Redland Engineering Limited. Gyp-Crete is a trademark owned by Maxxon Corporation. The Home Innovation NGBS Green Certified logo is a trademark of Home Innovation Research Labs. Sustainable Forestry Initiative and SFI are trademarks of Sustainable Forestry Initiative, Inc.
©2014 Georgia-Pacific Wood Products LLC. All rights reserved. Printed in the U.S.A. 1/14 TM Lit. Item #123040.